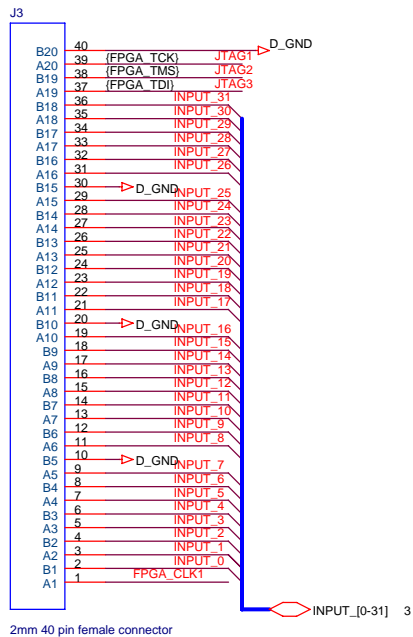

TABLE OF CONTENTS

MAIN.....1	MICRO.....4
CONNECTOR.....2	POWER.....5
FPGA.....3	USB.....6

Christian Föhr		
Mobile Satellite Services 18221A Flower Hill Way Gaithersburg, MD 20879		
Title ComBlock-1100 / MAIN		
Size A	Document Number Y02014	Rev 3
Date: Thursday, August 02, 2007	Sheet 1	of 6

40 Pin INPUT - Left



40 Pin OUTPUT - Bottom

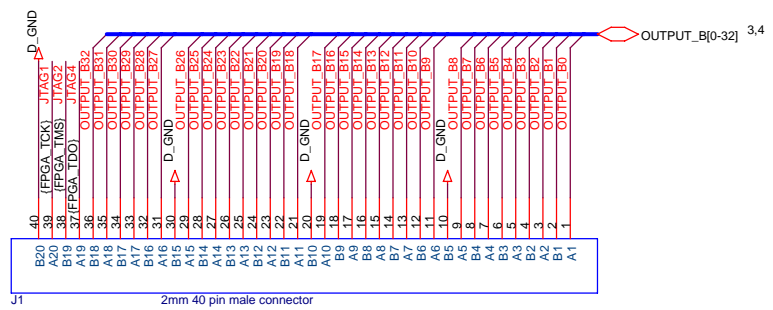

40 Pin OUTPUT - Right

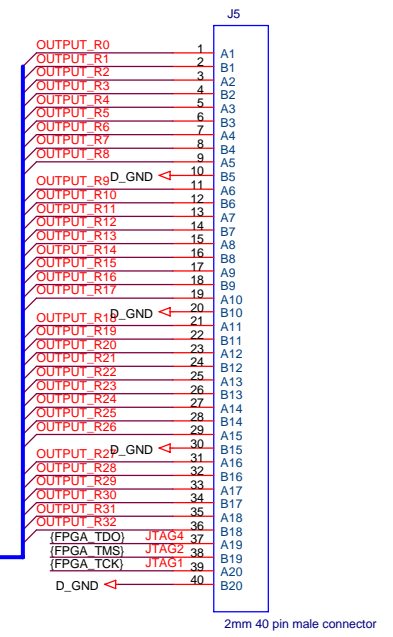

3 FPGA_CLK1

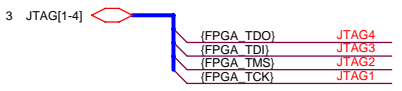

3 OUTPUT_R[0-32]

Christian Föhr Mobile Satellite Services 18221A Flower Hill Way Gaithersburg, MD 20879 USA		
Title ComBlock-1100 / CONNECTOR		
Size B	Document Number Y02014	Rev 3
Date: Thursday, August 02, 2007	Sheet 2	of 6

USB INTERFACE

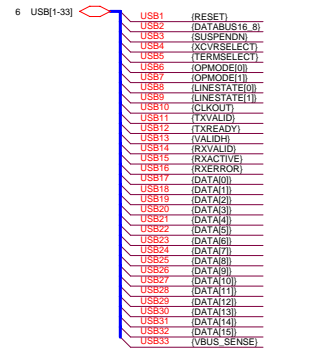

FPGA CONFIGURATION

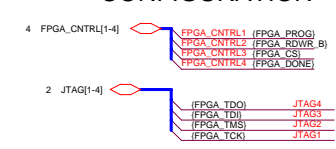

uC INTERFACE

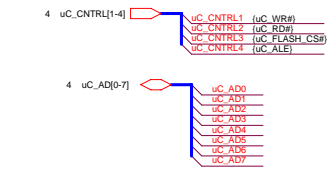

FPGA CLOCKS

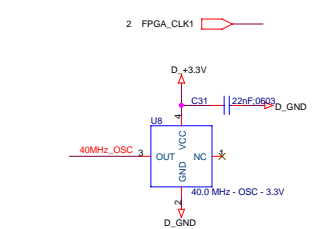

FPGA

40 PIN OUTPUT - BOTTOM



40 PIN INPUT - RIGHT

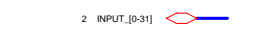

40 PIN OUTPUT - LEFT



FPGA TP1	1	1	10	FPGA TP10
FPGA TP2	2	2	9	FPGA TP9
FPGA TP3	3	3	8	FPGA TP8
FPGA TP4	4	4	7	FPGA TP7
FPGA TP5	5	5	6	FPGA TP6

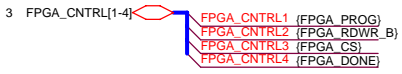

IN CIRCUIT PROGRAMMING HEADER

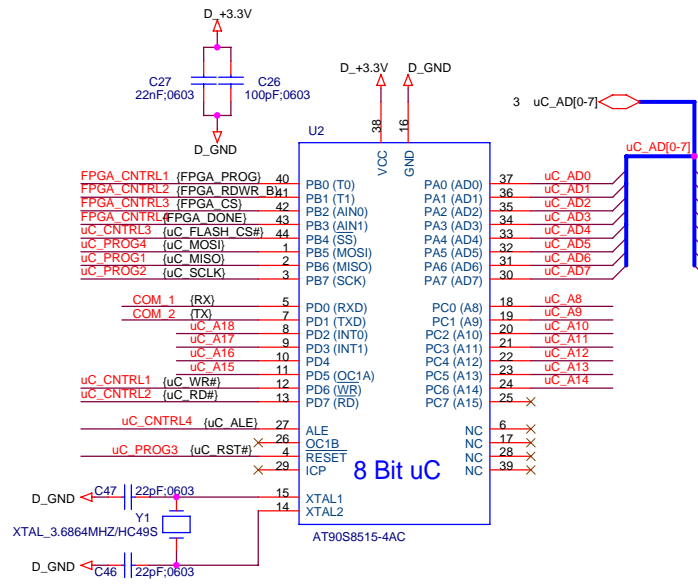
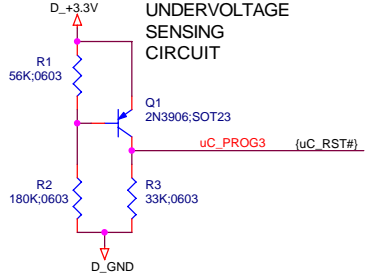
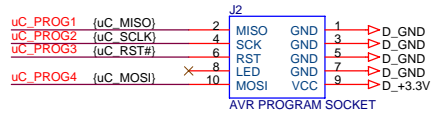

ADDRESS LATCH [A0 - A7]

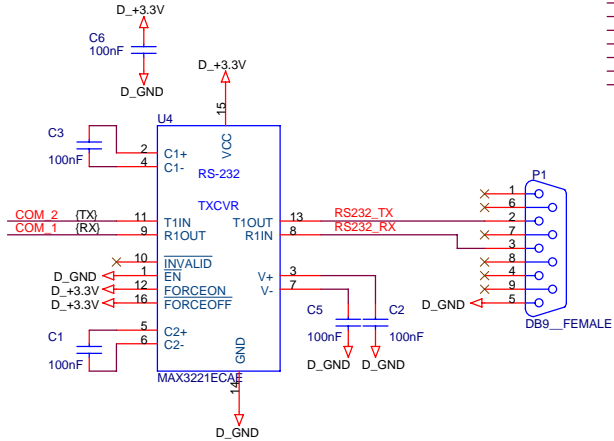
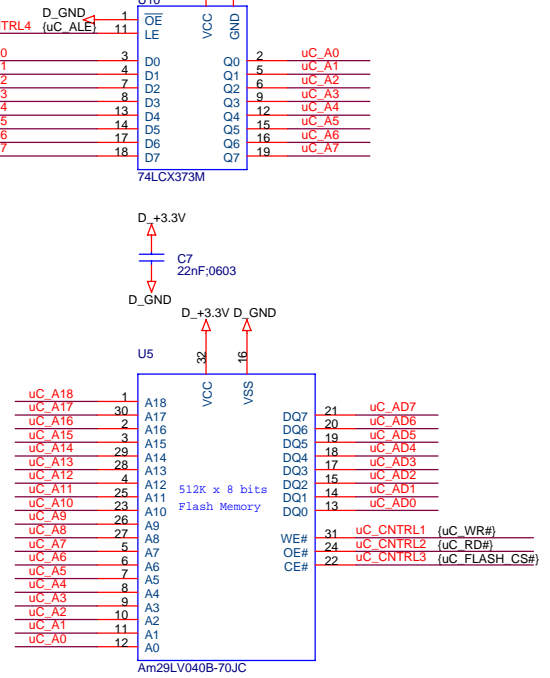

Christian Föhr
 Mobile Satellite Services
 18221A Flower Hill Way
 Gaithersburg, MD 20879
 USA

Title: **ComBlock-1100 / MICROCONTROLLER**

Size: B, Document Number: Y02014, Rev: 3

Date: Thursday, August 02, 2007, Sheet: 4 of 6

+5 V Supply

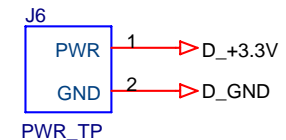
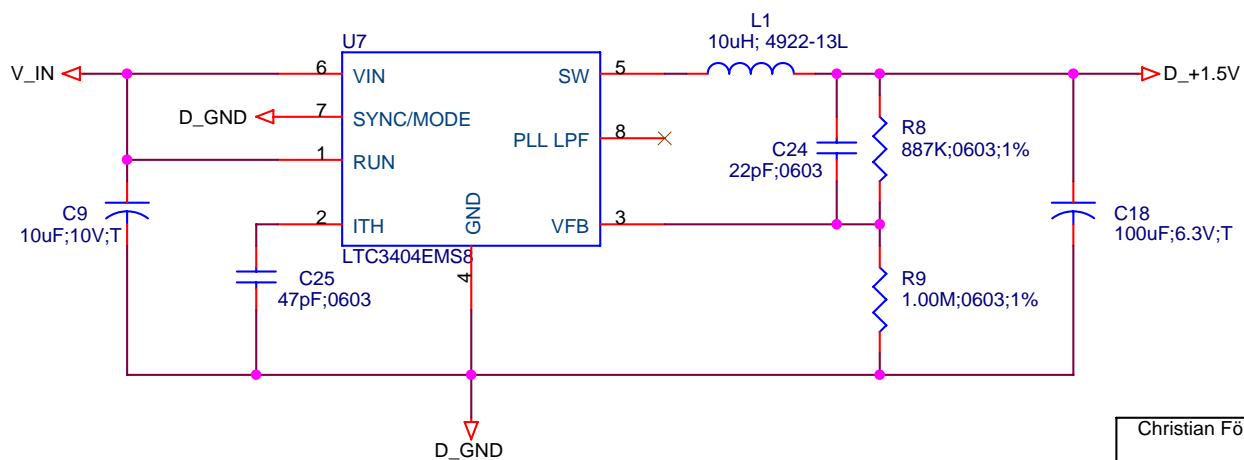
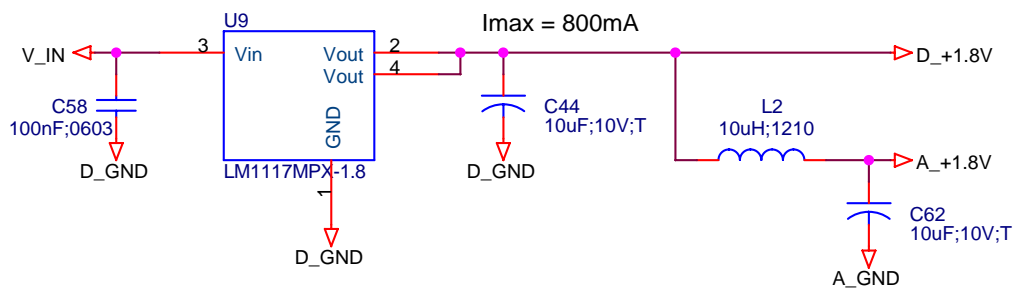
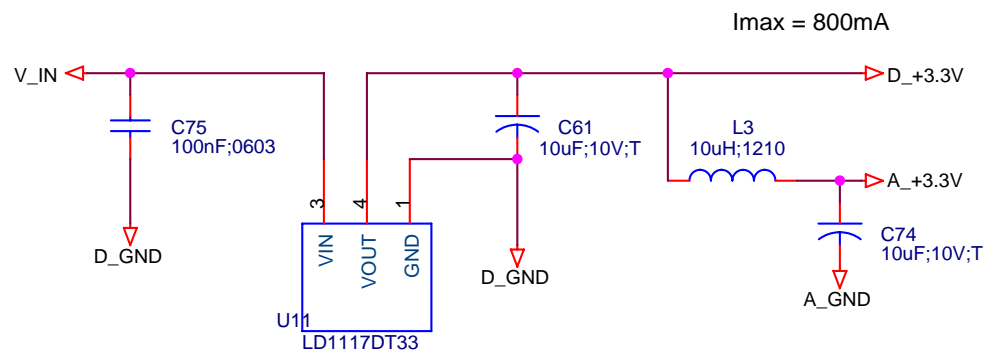
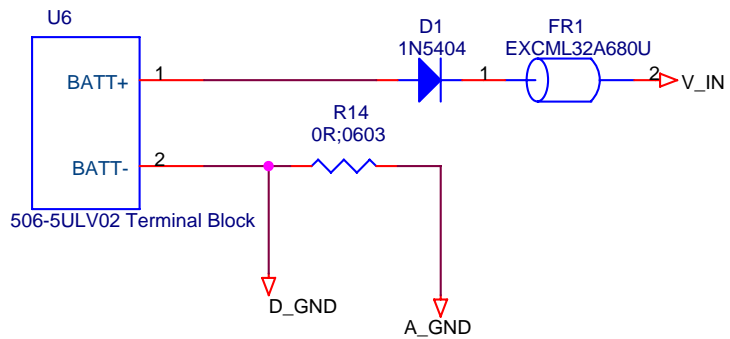

Christian Föhr		
Mobile Satellite Services 18221A Flower Hill Way Gaithersburg, MD 20879 USA		
Title ComBlock-1100 / POWER		
Size A	Document Number Y02014	Rev 3
Date: Thursday, August 02, 2007	Sheet 5	of 6

