

DIGITAL\_CONNECTORS

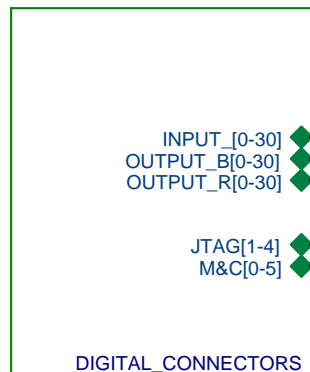

FPGA

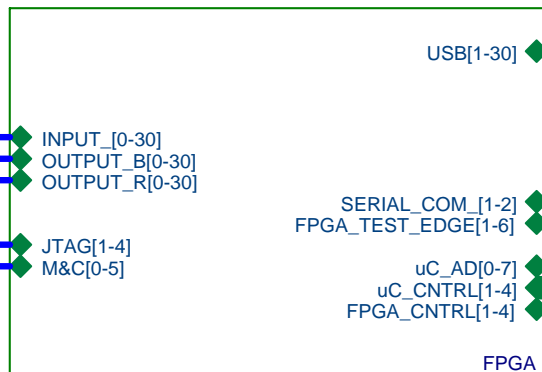

USB

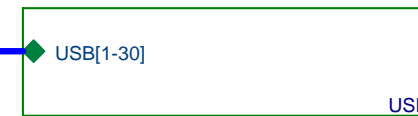

MICRO

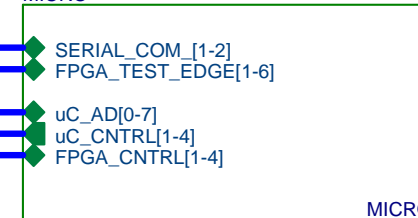

POWER



INPUT\_[0-30]  
OUTPUT\_B[0-30]  
OUTPUT\_R[0-30]

JTAG[1-4]  
M&C[0-5]

INPUT\_[0-30]  
OUTPUT\_B[0-30]  
OUTPUT\_R[0-30]

JTAG[1-4]  
M&C[0-5]

SERIAL\_COM\_[1-2]  
FPGA\_TEST\_EDGE[1-6]

uC\_AD[0-7]  
uC\_CNTRL[1-4]  
FPGA\_CNTRL[1-4]

USB[1-30]

SERIAL\_COM\_[1-2]  
FPGA\_TEST\_EDGE[1-6]

uC\_AD[0-7]  
uC\_CNTRL[1-4]  
FPGA\_CNTRL[1-4]

USB[1-30]

SERIAL\_COM\_[1-2]  
FPGA\_TEST\_EDGE[1-6]

uC\_AD[0-7]  
uC\_CNTRL[1-4]  
FPGA\_CNTRL[1-4]

TABLE OF CONTENTS

|                    |   |       |   |
|--------------------|---|-------|---|
| MAIN               | 1 | MICRO | 4 |
| DIGITAL_CONNECTORS | 2 | POWER | 5 |
| FPGA               | 3 | USB   | 6 |

AK

Mobile Satellite Services  
18221A Flower Hill Way  
Gaithersburg, MD 20879

Title  
**COM 1400 / Main**

|           |                                  |          |
|-----------|----------------------------------|----------|
| Size<br>A | Document Number<br><b>Y05001</b> | Rev<br>3 |
|-----------|----------------------------------|----------|

Date: Tuesday, August 26, 2008      Sheet 1 of 6

INPUT\_[0-30]

3 OUTPUT\_B[0-30]

3 OUTPUT\_R[0-30]

J5

J9

J8

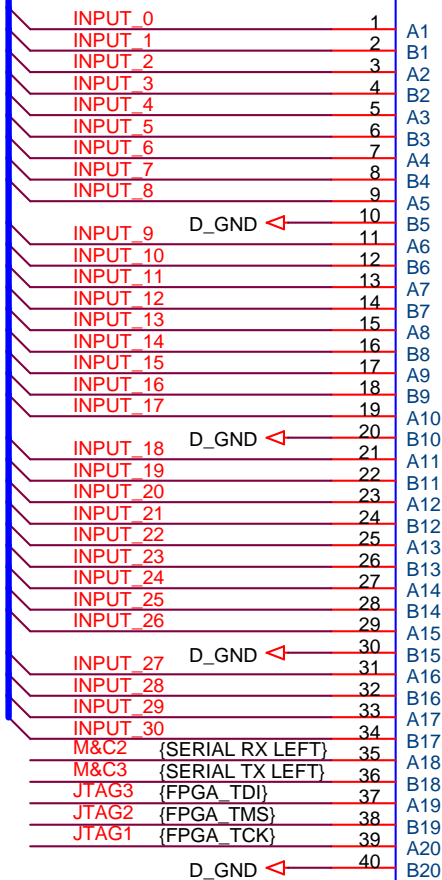

SQT-120-01-L-D-RA

DIGITAL INPUT  
LEFT  
CONNECTOR

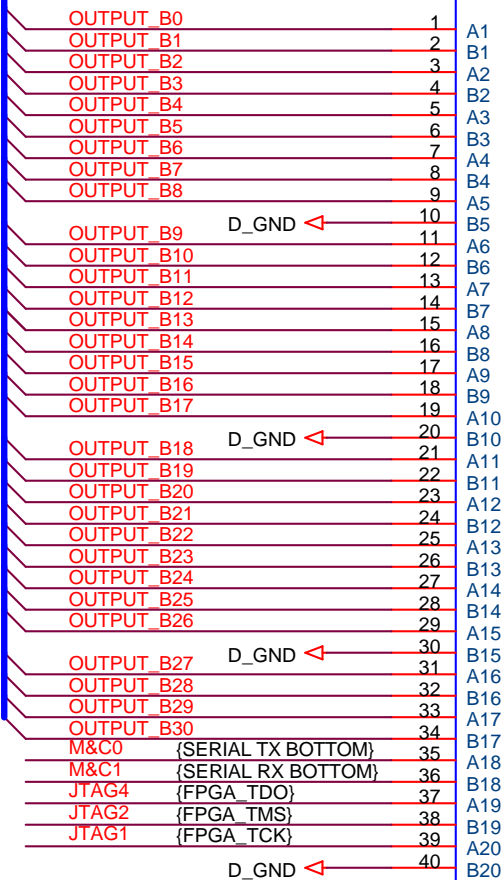

TMMH-120-01-L-D-RA

DIGITAL OUTPUT  
BOTTOM  
CONNECTOR

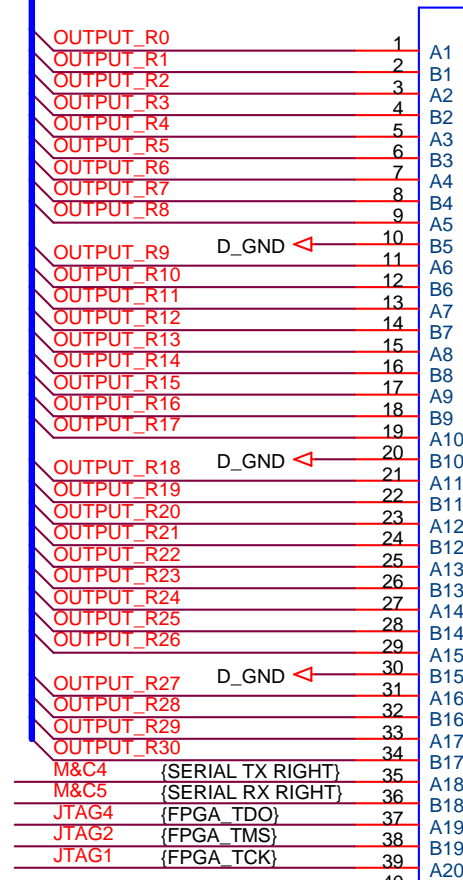

TMMH-120-01-L-D-RA

DIGITAL OUTPUT  
RIGHT  
CONNECTOR

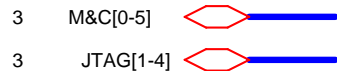

|   |                                  |          |
|---|----------------------------------|----------|
| AK  |                                  |          |
| Mobile Satellite Services<br>18221A Flower Hill Way<br>Gaithersburg, MD 20879 |                                  |          |
| Title<br><b>COM-1400 / DIGITAL CONNECTORS</b>                                 |                                  |          |
| Size<br>A   | Document Number<br><b>Y05001</b> | Rev<br>3 |
| Date: Tuesday, August 26, 2008  | Sheet 2 of 6                     |          |

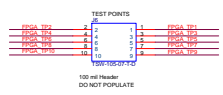
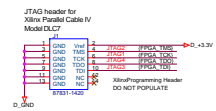

**USB INTERFACE**



**40 PIN DIGITAL CONNECTORS**



**FPGA CONFIGURATION**



**uC INTERFACE**

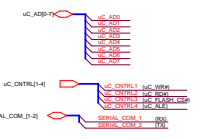

**TEST POINTS**

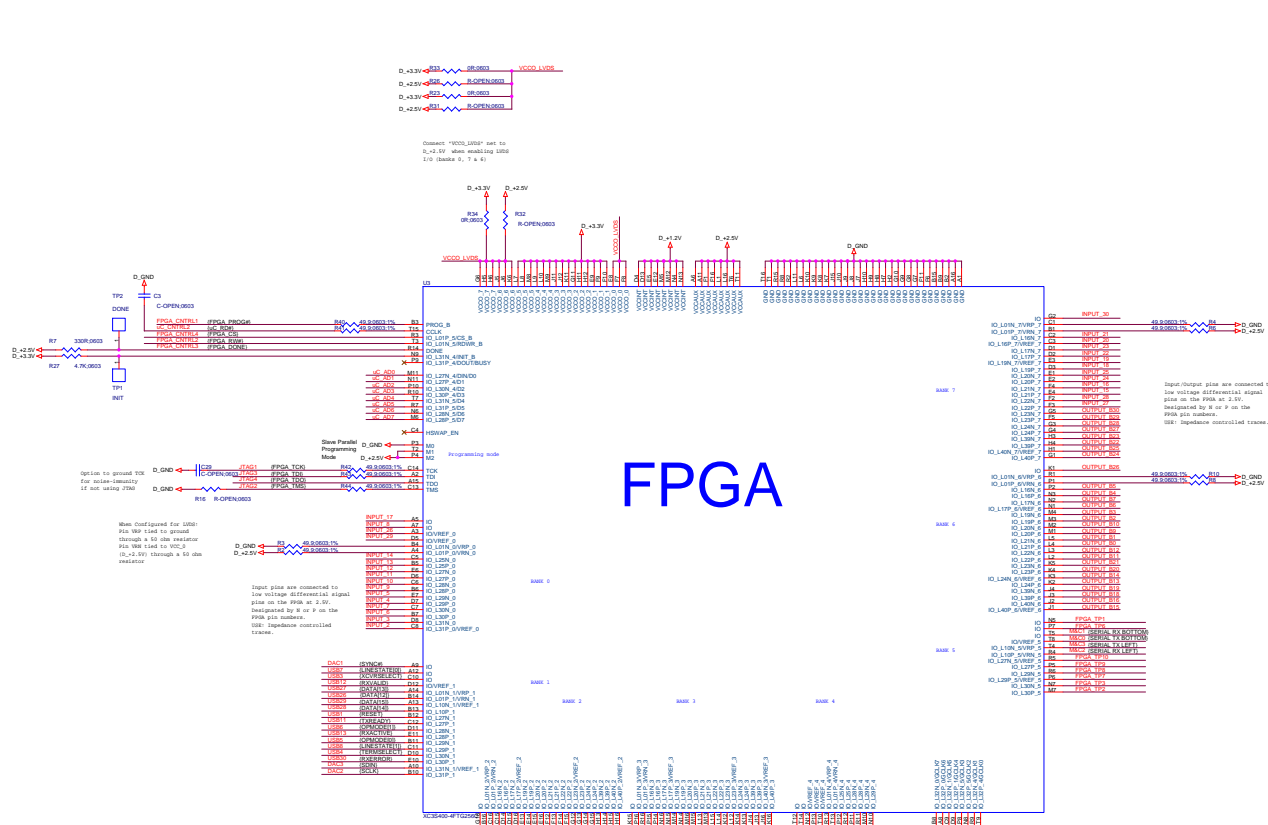
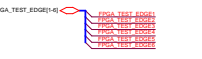

**FPGA**

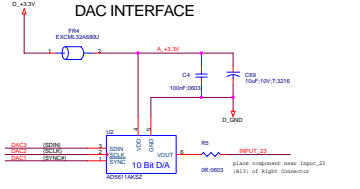
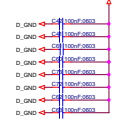
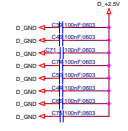
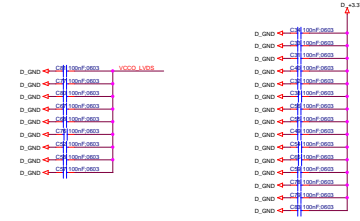

|  |                |
|--|----------------|
| Xilinx<br>Model: Xilinx Parallel Cable IV<br>Model: Xilinx Parallel Cable IV<br>Model: Xilinx Parallel Cable IV<br>Model: Xilinx Parallel Cable IV |                |
| Part   | COM-1400/ FPGA |
| Rev  | Y05001         |
| Date   | 05/05/2008     |

# FPGA TEST POINTS

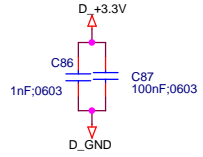
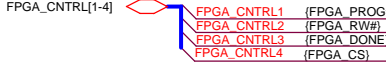
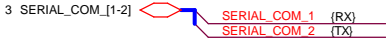
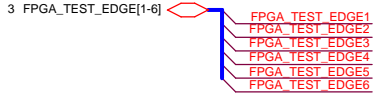

## ADDRESS LATCH [A0 - A7]

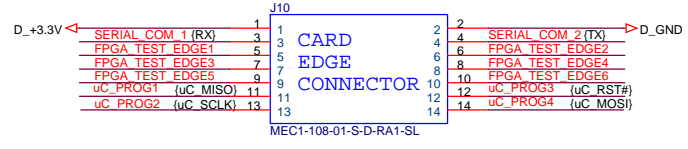
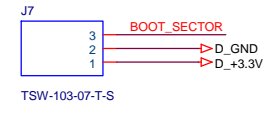
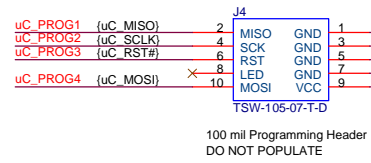
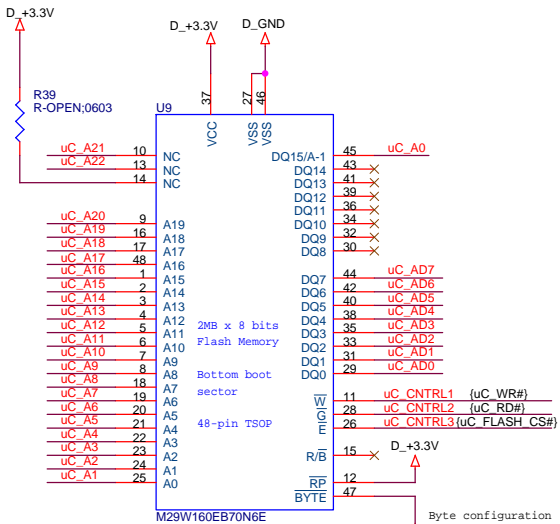
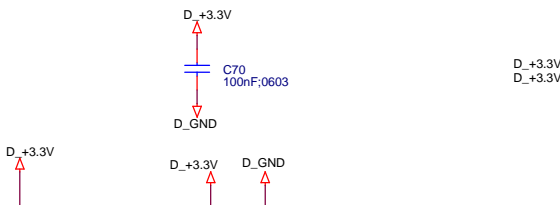
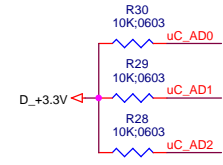
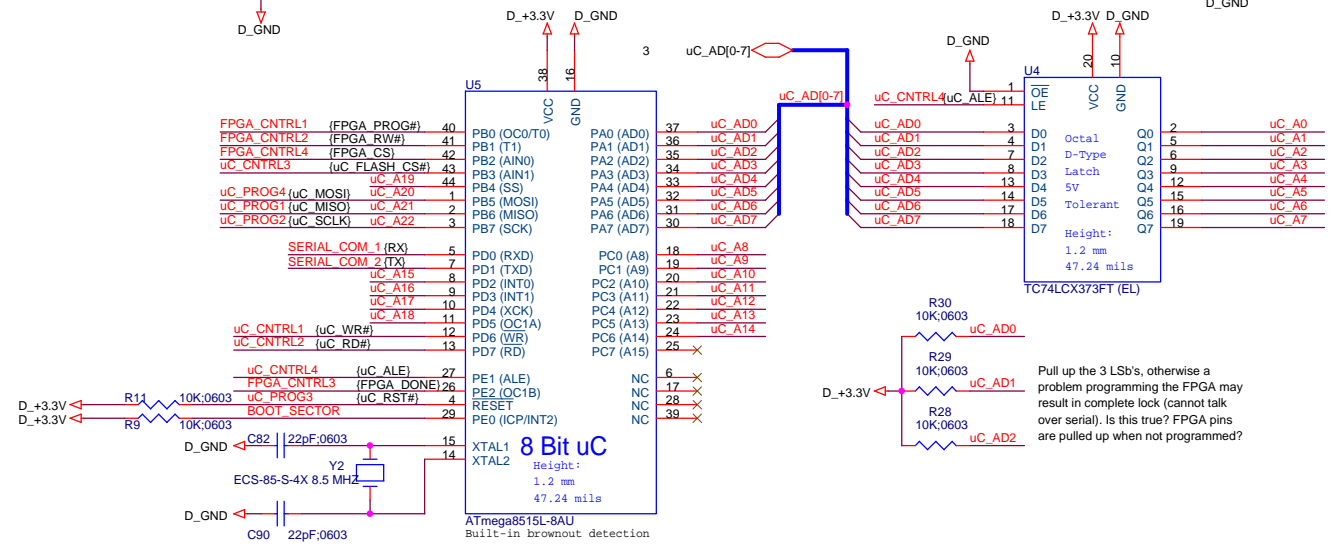
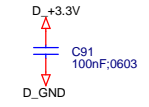

Please note:  
Serial link is LVTTTL, NOT RS232.

|  |                                  |          |
|--|----------------------------------|----------|
| AK<br>Mobile Satellite Services<br>18221A Flower Hill Way<br>Gaithersburg, MD 20879<br>USA |                                  |          |
| Title<br><b>COM-1400/ MICROCONTROLLER</b>  |                                  |          |
| Size<br>B  | Document Number<br><b>Y05001</b> | Rev<br>3 |
| Date:<br>Tuesday, August 26, 2008  | Sheet<br>4                       | of<br>6  |

# +5 V Supply

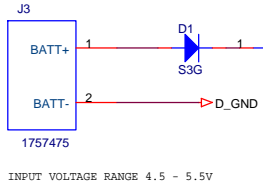

USB3250 max total power consumption: 185mW (HS mode)  
Thus linear regulators are sufficient

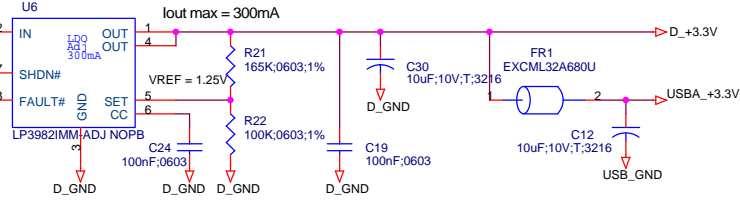

FPGA Vcc aux max power consumption: 50mW

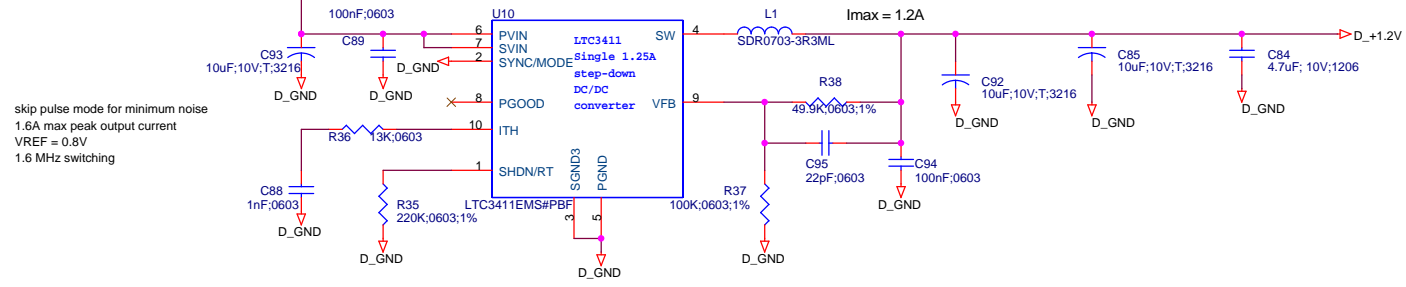
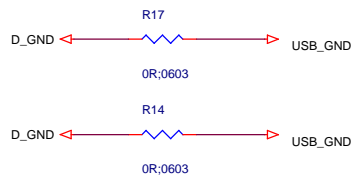
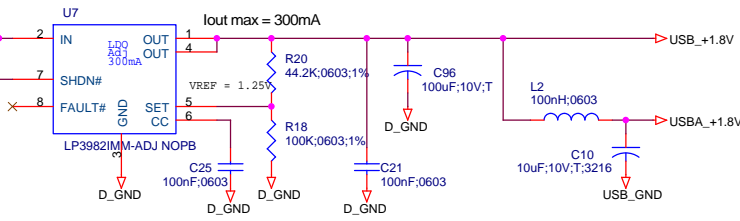
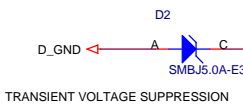
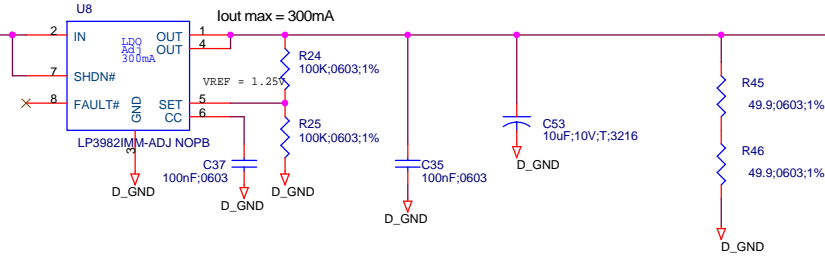

|  |                                  |          |
|--|----------------------------------|----------|
| AK<br>Mobile Satellite Services<br>18221A Flower Hill Way<br>Gaithersburg, MD 20879<br>USA |                                  |          |
| Title<br><b>COM-1400 / POWER</b>   |                                  |          |
| Size<br>B  | Document Number<br><b>Y05001</b> | Rev<br>3 |
| Date:<br>Tuesday, August 26, 2008  | Sheet<br>5 of 6                  |          |

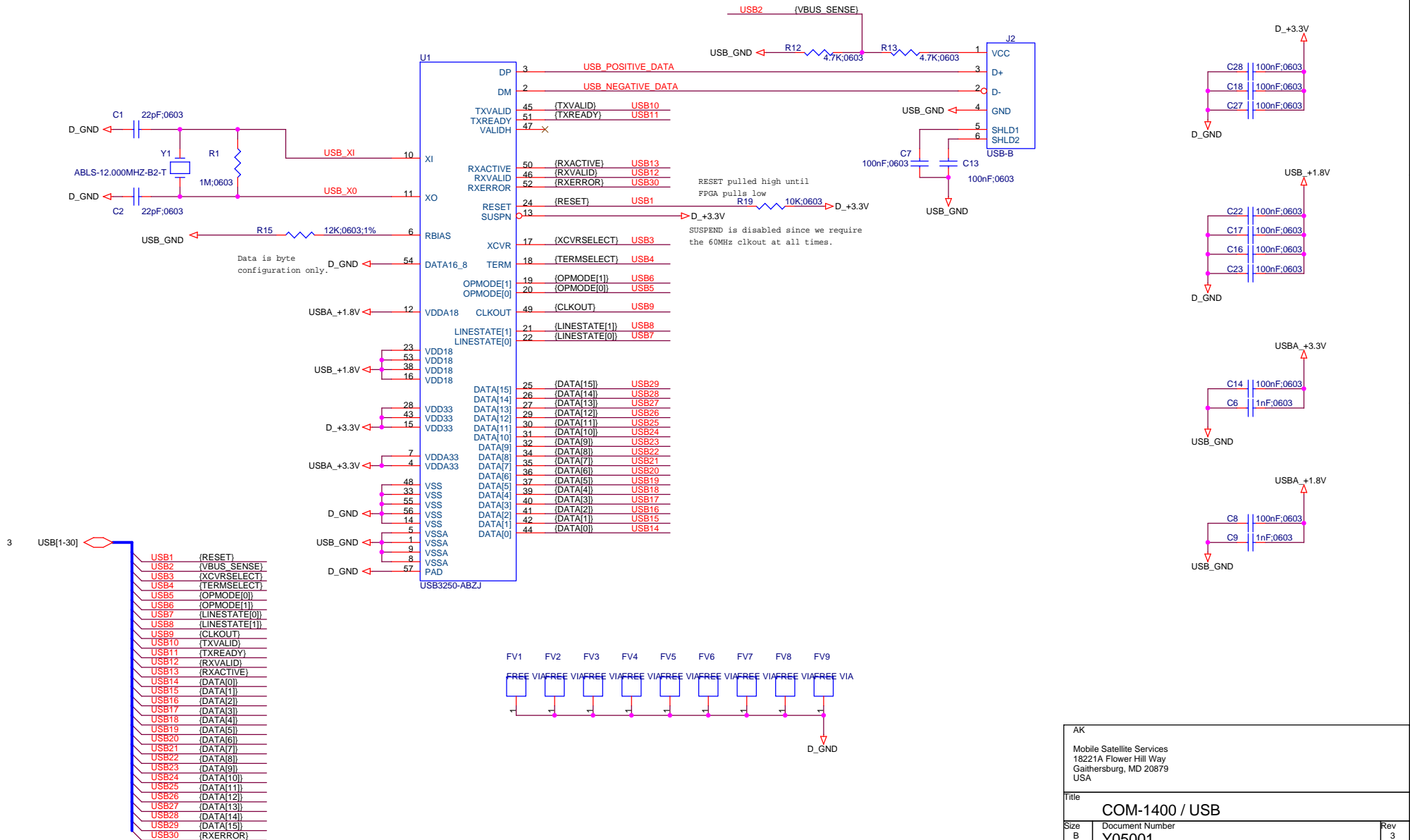

AK  
 Mobile Satellite Services  
 18221A Flower Hill Way  
 Gaithersburg, MD 20879  
 USA

Title  
**COM-1400 / USB**

Size B Document Number  
**Y05001**

Date: Tuesday, August 26, 2008 Sheet 6 of 6 Rev 3