

Sheet	Description
1	MAIN
2	POWER
3	CONNECTOR
4	DAC
5	LOW PASS FILTER
6	MICRO

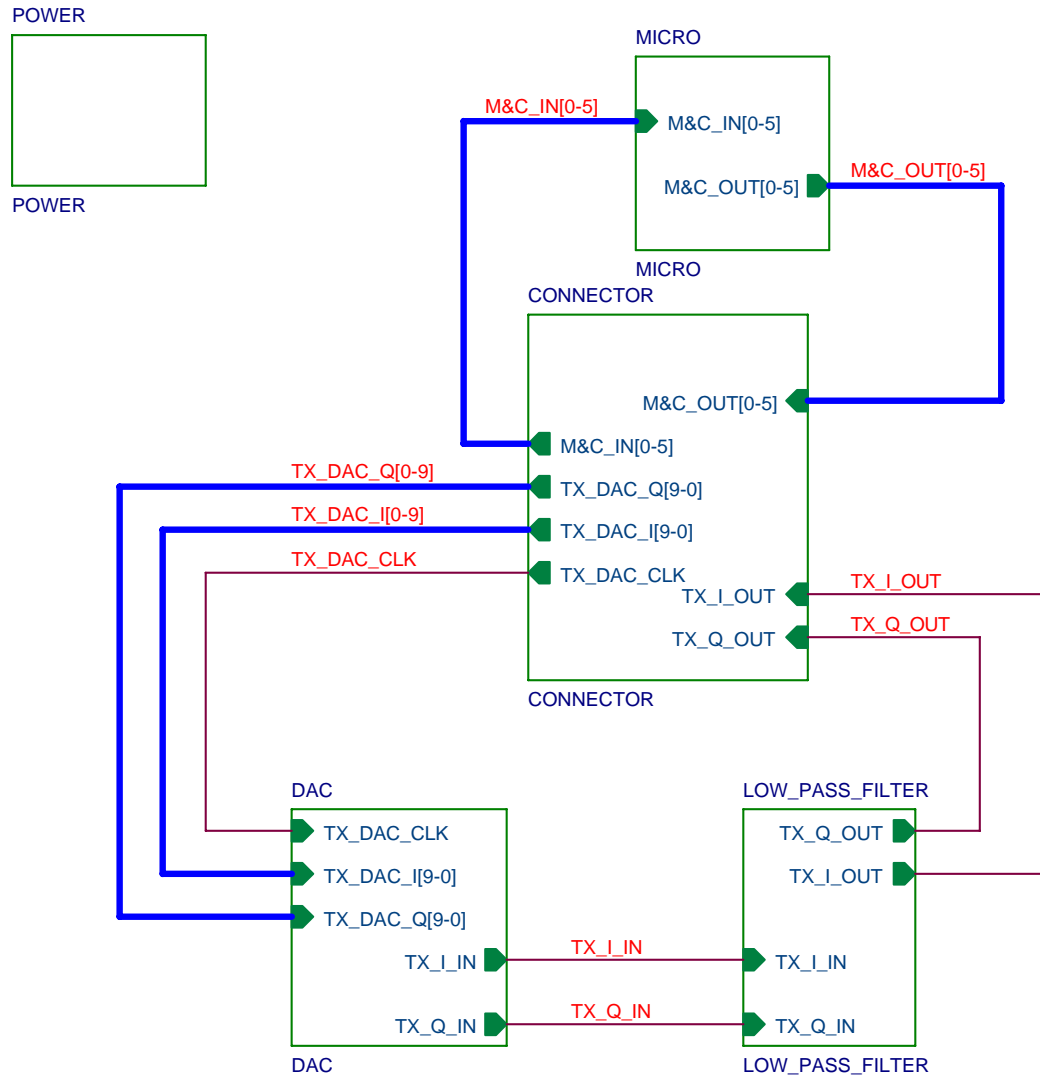

Mobile Satellite Services		
Michael J. Yoha 18221A Flower Hill Way Gaithersburg, MD 20879 USA		
Title <b>ComBlock 2001 / MAIN</b>		
Size A	Document Number <b>Y01008</b>	Rev 1
Date:	Wednesday, October 26, 2005	Sheet 1 of 6

**+5 V Supply**

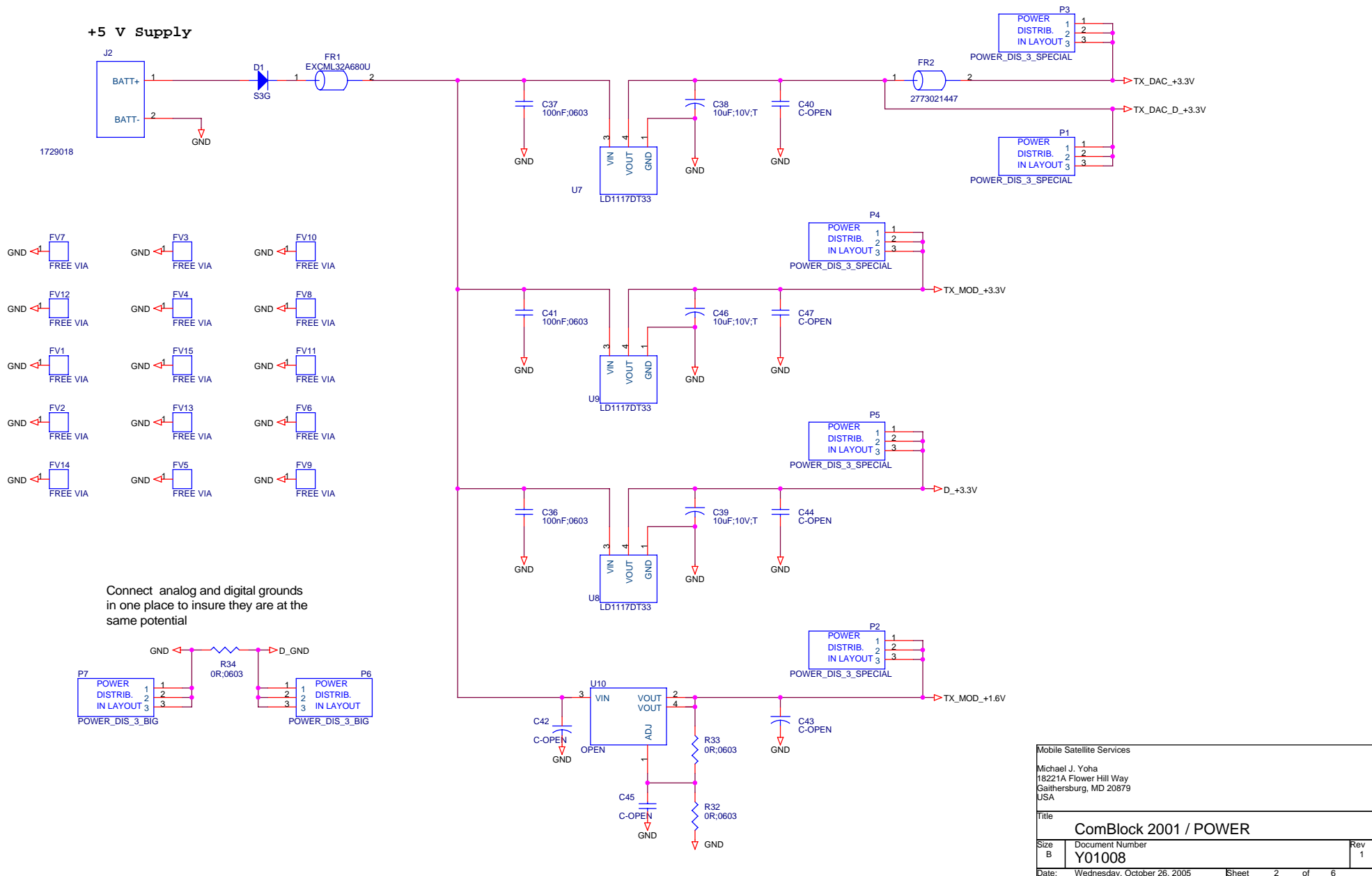

Connect analog and digital grounds in one place to insure they are at the same potential

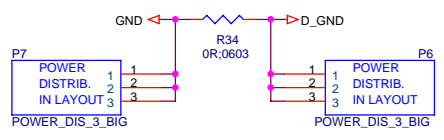

Mobile Satellite Services		
Michael J. Yoha 18221A Flower Hill Way Gaithersburg, MD 20879 USA		
Title	ComBlock 2001 / POWER	
Size	Document Number	Rev
B	Y01008	1
Date:	Wednesday, October 26, 2005	Sheet 2 of 6

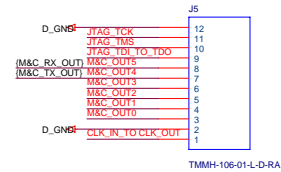
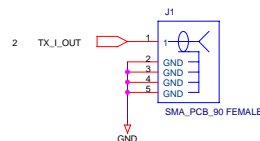
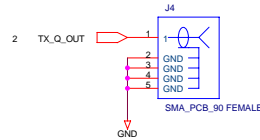
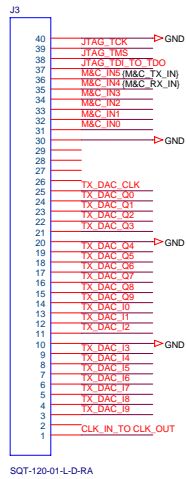
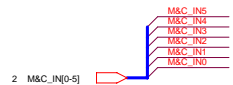
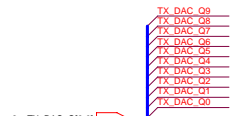
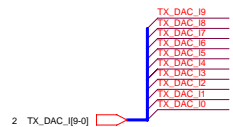

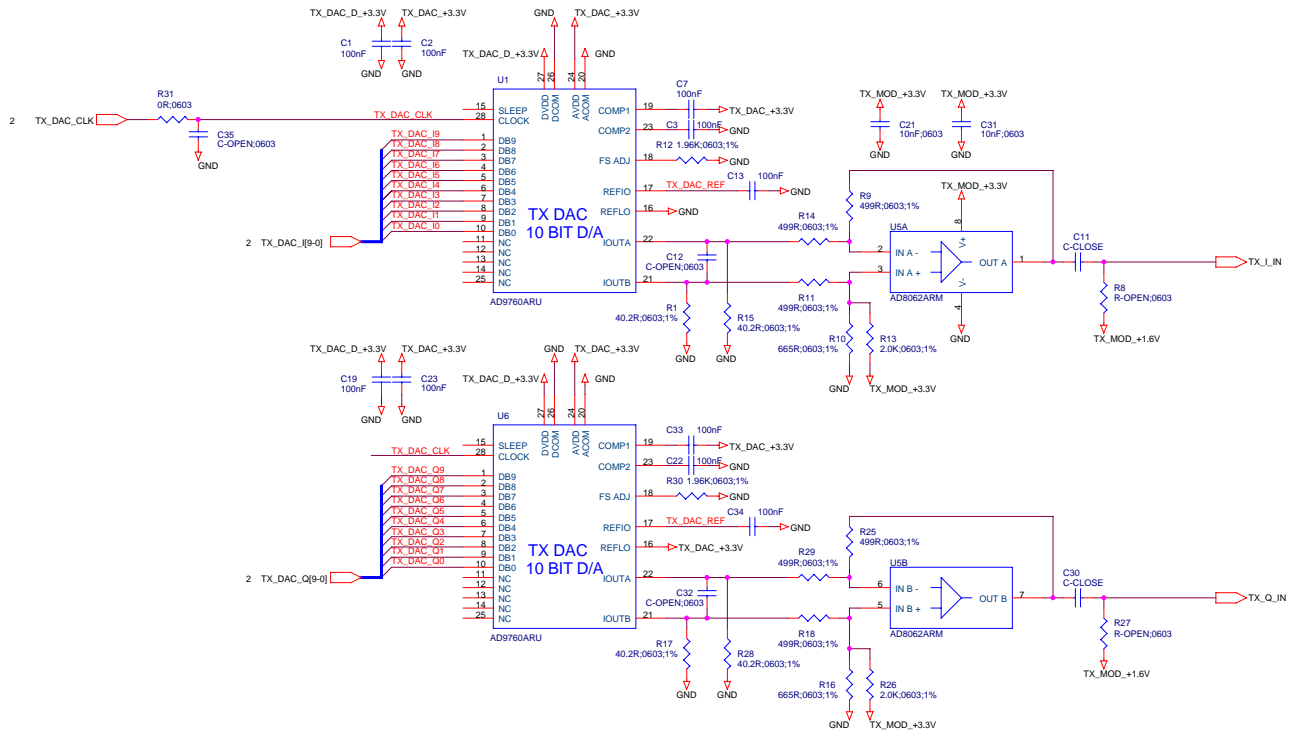

Anti-Alias Low Pass Filter  
 Unity Gain Sallen Key 6 Pole  
 Butterworth  
 $F(\text{cut-off}) = 13\text{MHz}$

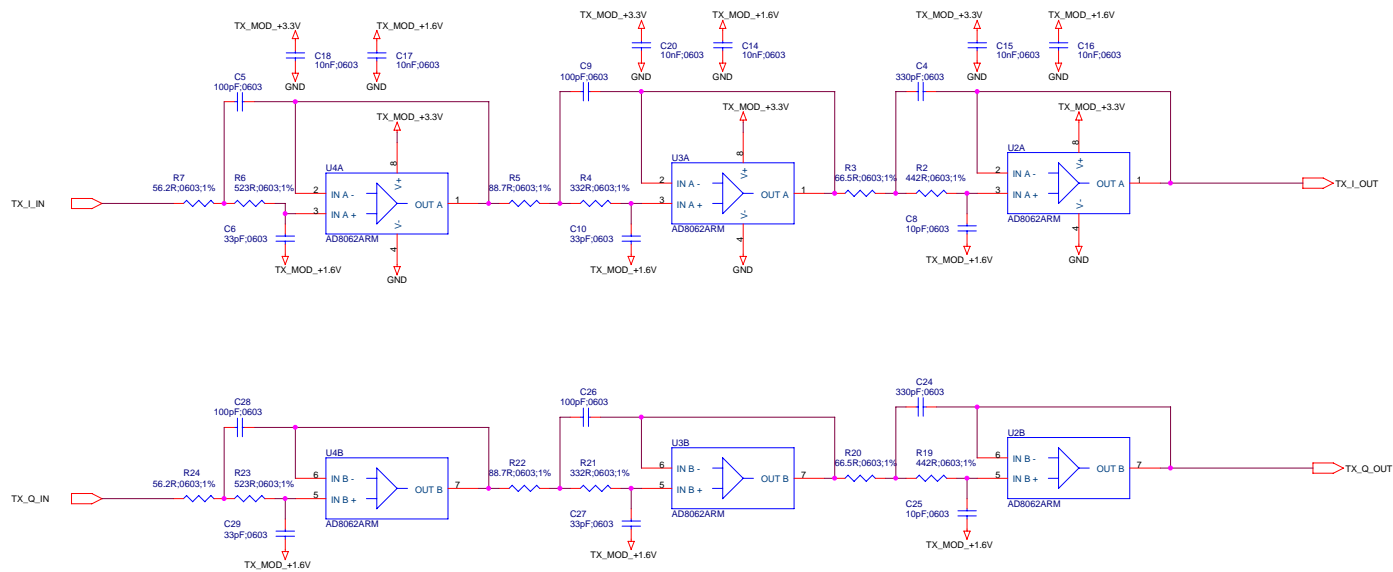

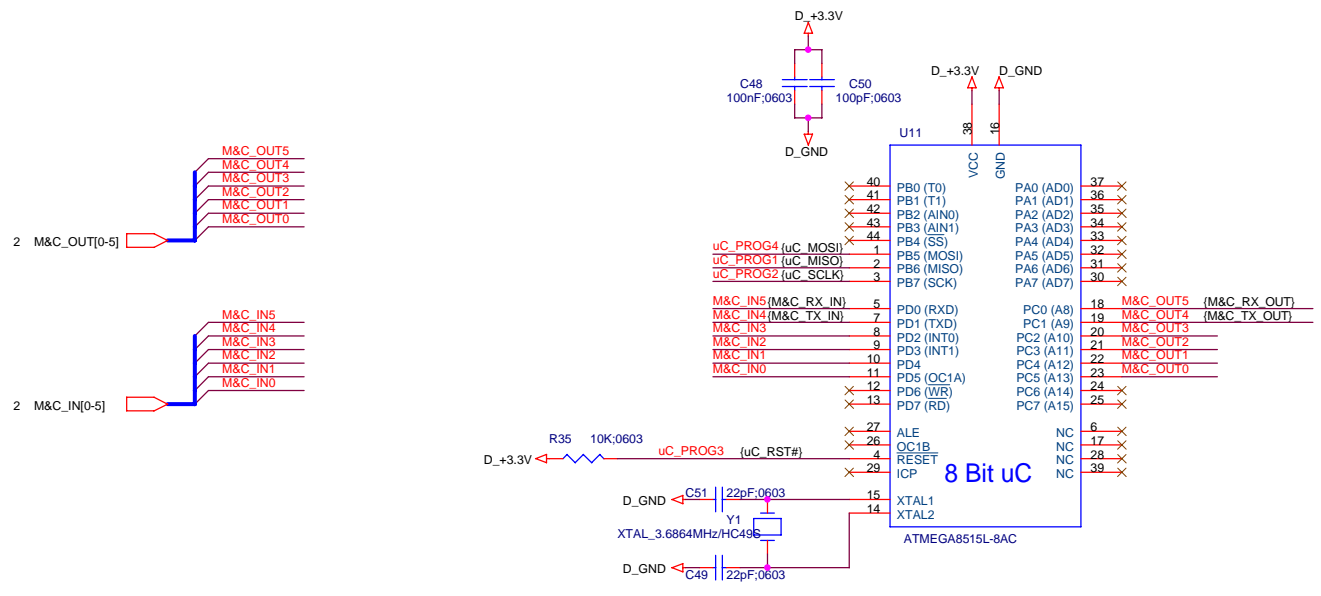

IN CIRCUIT  
PROGRAMMING HEADER

