

TABLE OF CONTENTS

MAIN..... 1
 ADC..... 2
 CONNECTOR..... 3
 DEMODULATOR..... 4
 FREQ SYNTH..... 5
 MICRO..... 6
 POWER..... 7
 LAYOUT..... 8

CLK_ADC_CNTRL

CLK_ADC_EXT

INT_CLK_ON_OFF

DFS

PDWN_A

PDWN_B

OEB_A

OEB_B

MUX_SELECT

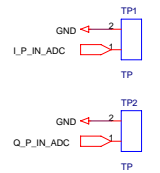
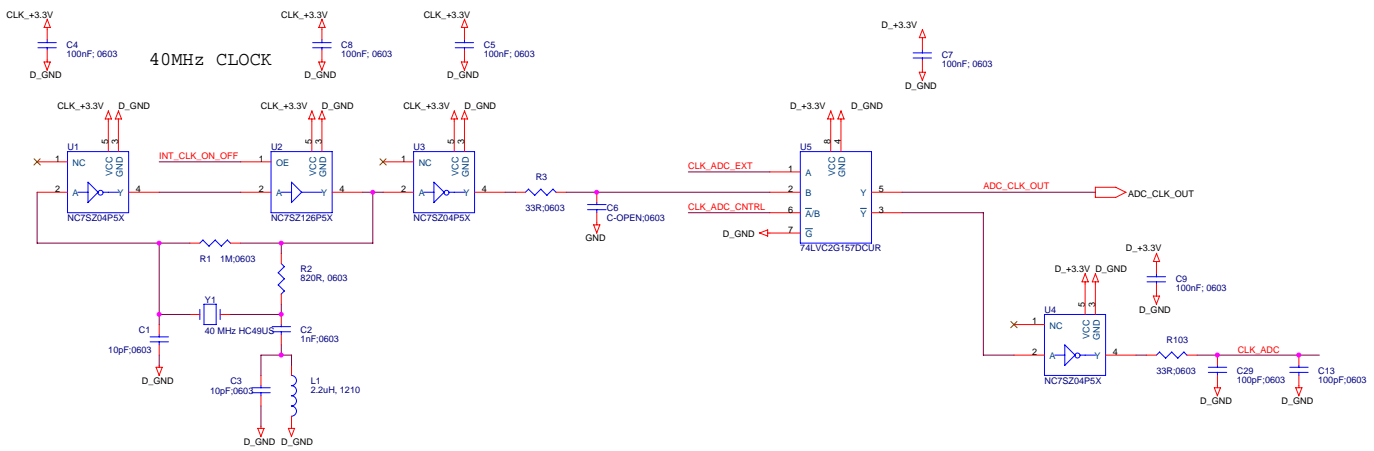
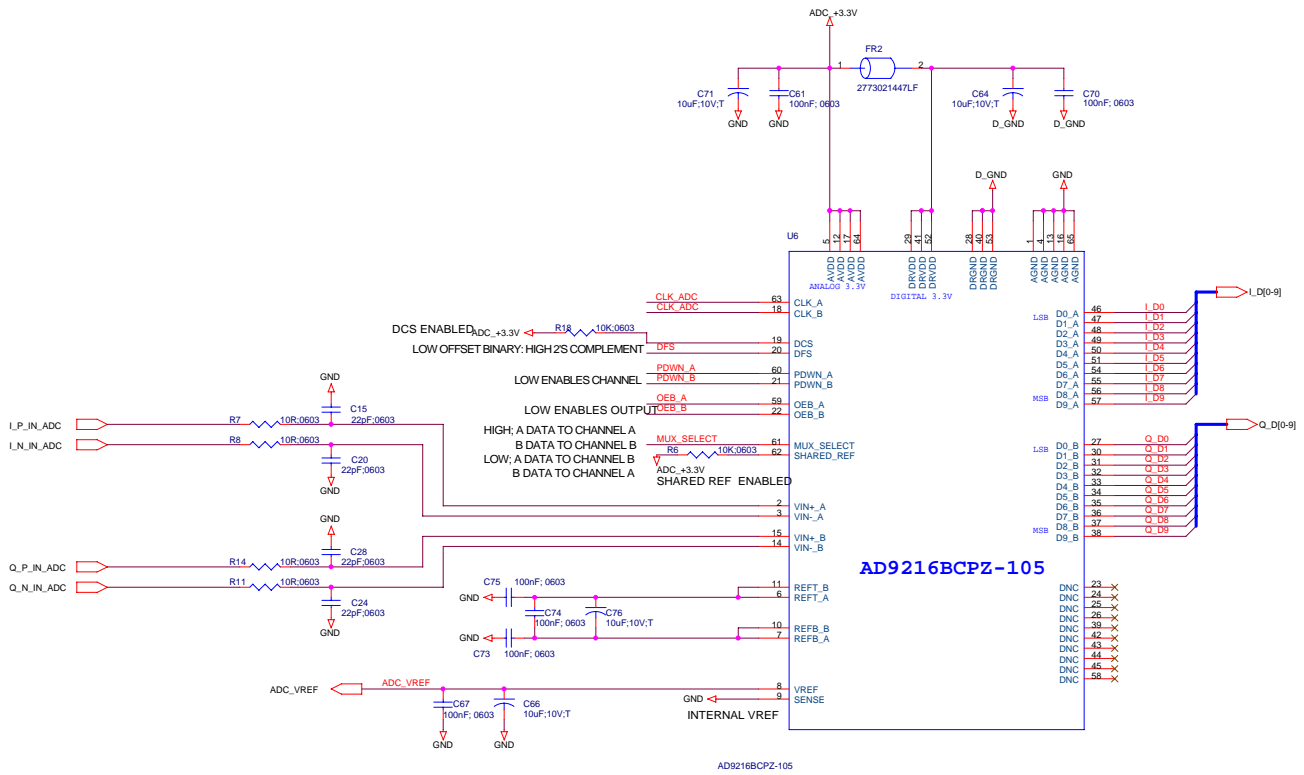

Mobile Satellite Services	
Michael J. Yoha 18221A Flower Hill Way Cathersburg, MD 20879 USA	
Title	ComBlock 3007 / ADC
Size	Document Number
C	Y06003
Date	Friday, September 01, 2006
Sheet	2 of 8
Rev	3

CLK_ADC_EXT ← CLK_ADC_EXT

AGC_IN ← AGC_IN

2ADC_CLK_OUT → ADC_CLK_OUT

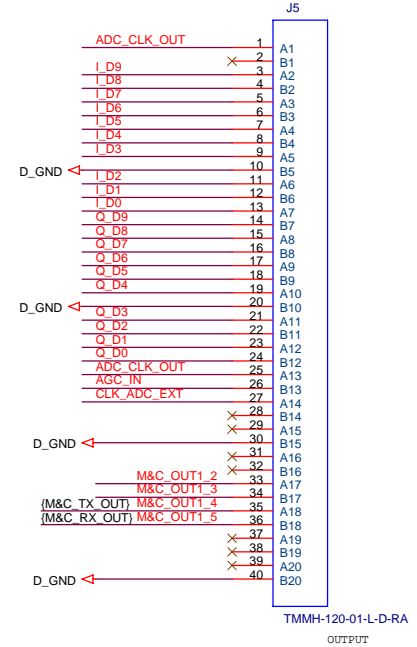
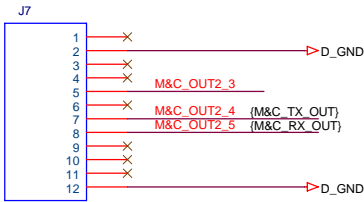
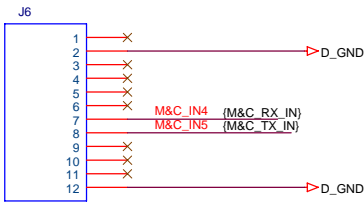
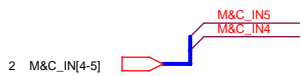
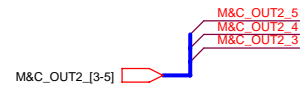
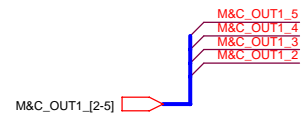
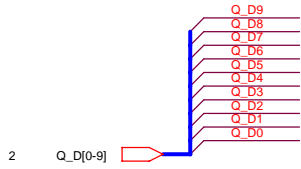
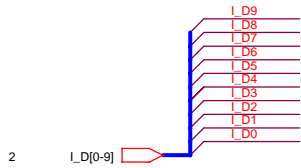

Mobile Satellite Services		
Michael J. Yoha 18221A Flower Hill Way Gaithersburg, MD 20879 USA		
Title ComBlock 3007 / Connector		
Size B	Document Number Y06003	Rev 3
Date: Friday, September 01, 2006	Sheet 3 of 8	

EXTERNAL FREQUENCY REFERENCE

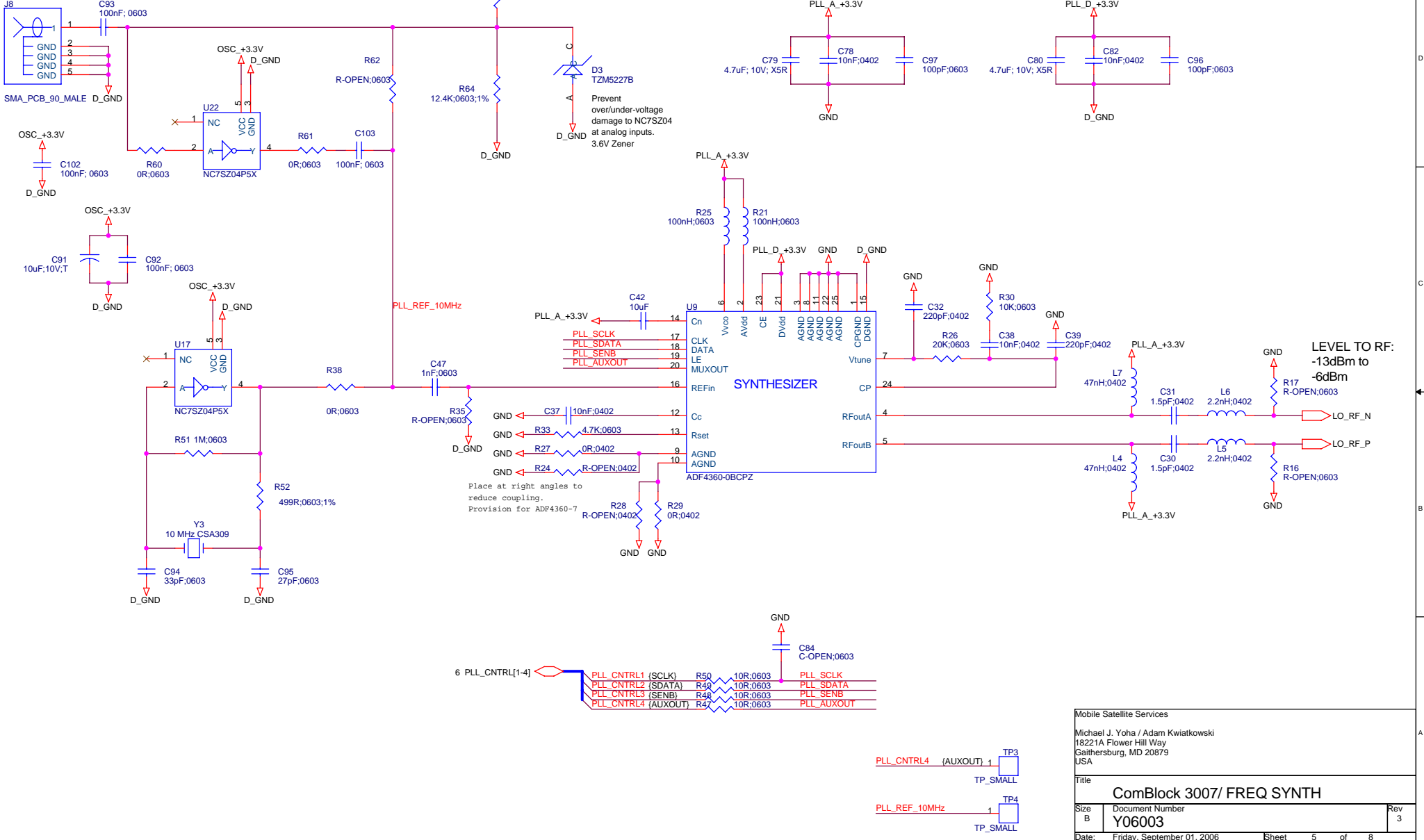

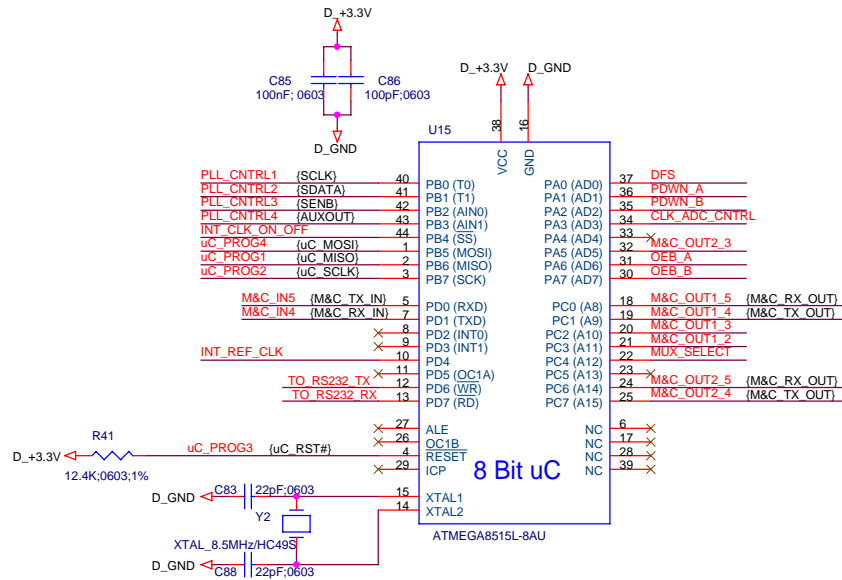
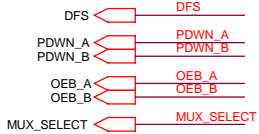
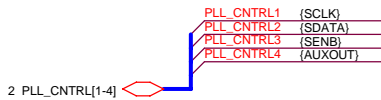
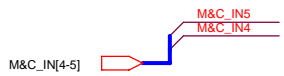
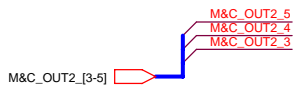
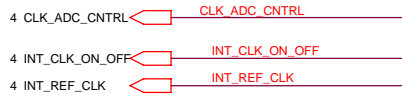

IN CIRCUIT PROGRAMMING HEADER

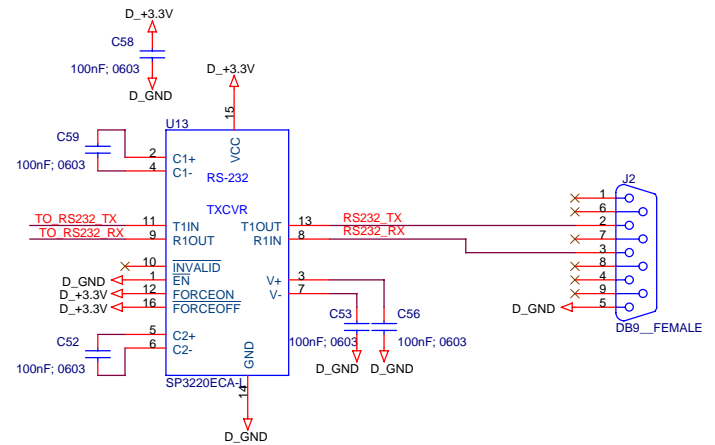
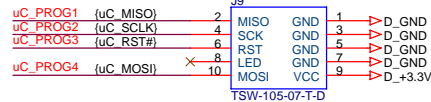

Mobile Satellite Services

Michael J. Yoha
18221A Flower Hill Way
Gaithersburg, MD 20879
USA

Title
ComBlock 3007 / MICRO

Size B Document Number Y06003

Rev 3

Date: Friday, September 01, 2006

Sheet 6 of 8

+5 V Supply

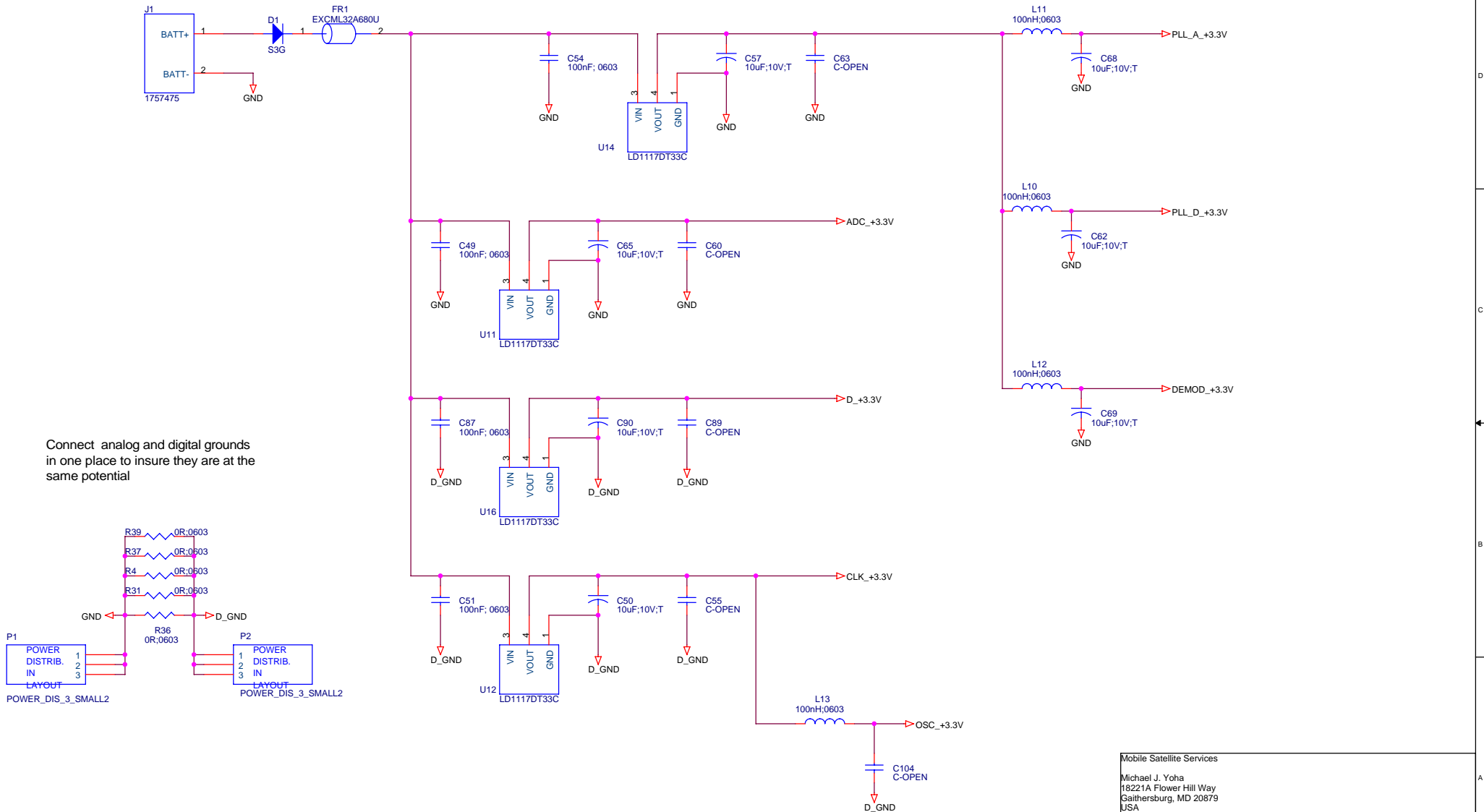

Connect analog and digital grounds in one place to insure they are at the same potential

Mobile Satellite Services		
Michael J. Yoha 18221A Flower Hill Way Gaithersburg, MD 20879 USA		
Title ComBlock 3007 / POWER		
Size B	Document Number Y06003	Rev 3
Date: Friday, September 01, 2006	Sheet 7	of 8

