

### TABLE OF CONTENTS

MAIN.....1	MICRO..... 4
ADC..... 2	POWER..... 5
CONNECTOR.....3	TUNER..... 6

MS		
Mobile Satellite Services 18221A Flower Hill Way Gaithersburg, MD 20879 USA		
Title		
<b>COM-3010 / MAIN</b>		
Size A	Document Number <b>Y08001</b>	Rev 3
Date: Thursday, June 24, 2010	Sheet 1 of 6	

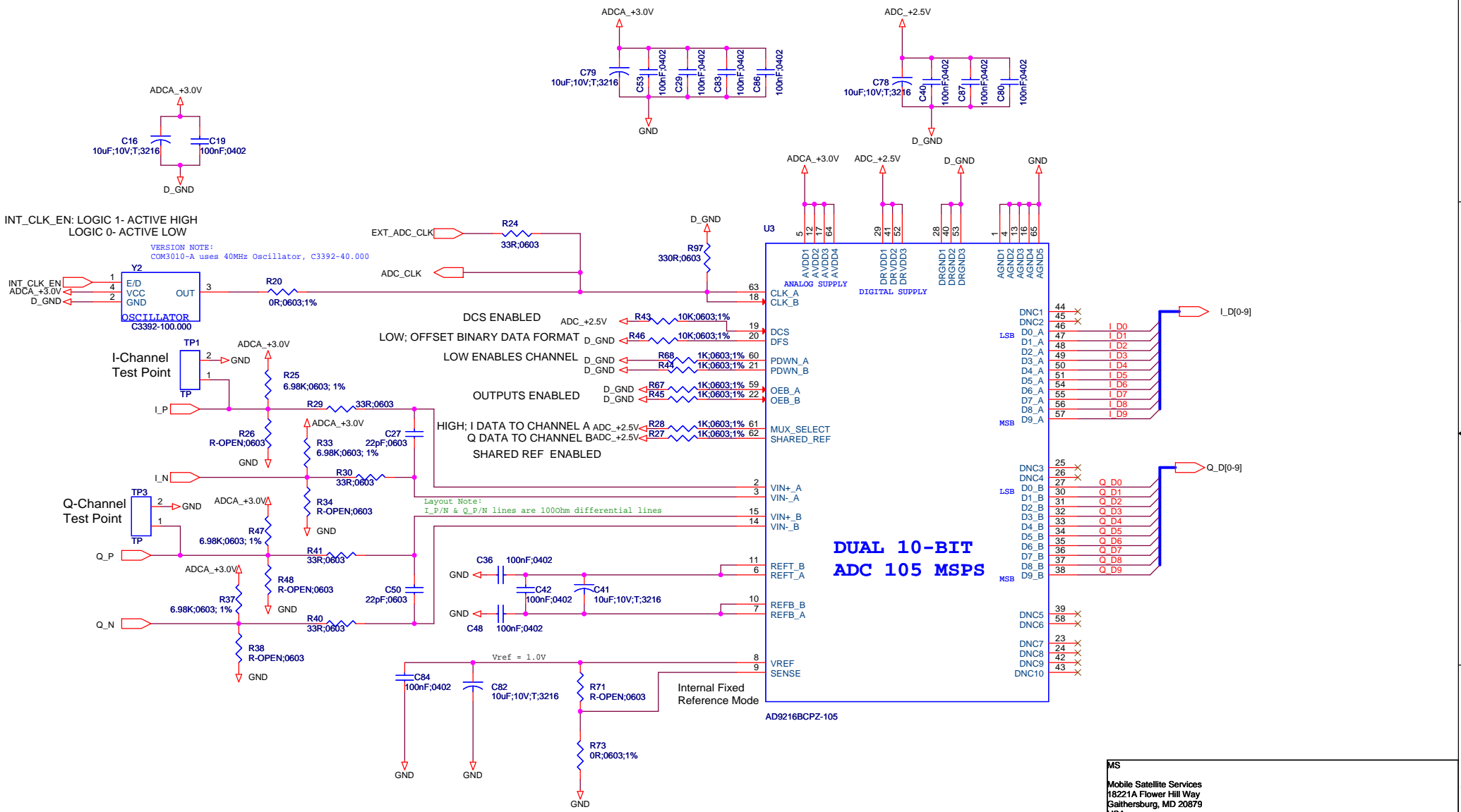

MS	
Mobile Satellite Services 18221A Flower Hill Way Gaithersburg, MD 20879 JUSA	
Title <b>COM-3010 / ADC</b>	
Size B	Document Number <b>Y08001</b>
Date: Thursday, June 24, 2010	Sheet 2 of 6
Rev 3	

External ADC sampling clock (input)  
EXT\_ADC\_CLK ← EXT\_ADC\_CLK

Input AGC (input)  
AGC\_IN ← AGC\_IN

ADC sampling clock (output)  
ADC\_CLK → ADC\_CLK

PLL\_REF → PLL\_REF

M&C\_OUT1\_[4-5] → M&C\_OUT1\_5  
M&C\_OUT1\_4

M&C\_OUT2\_[4-5] → M&C\_OUT2\_5  
M&C\_OUT2\_4

I\_D[0-9] → I\_D9  
I\_D8  
I\_D7  
I\_D6  
I\_D5  
I\_D4  
I\_D3  
I\_D2  
I\_D1  
I\_D0

Q\_D[0-9] → Q\_D9  
Q\_D8  
Q\_D7  
Q\_D6  
Q\_D5  
Q\_D4  
Q\_D3  
Q\_D2  
Q\_D1  
Q\_D0

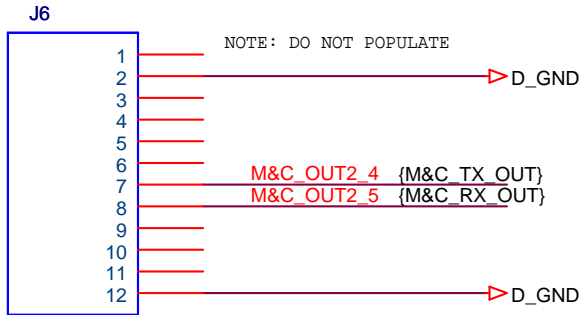

TMMH-106-01-L-D-RA

M&C OUTPUT TO  
EXTERNAL FREQ. REF  
MALE CONNECTOR

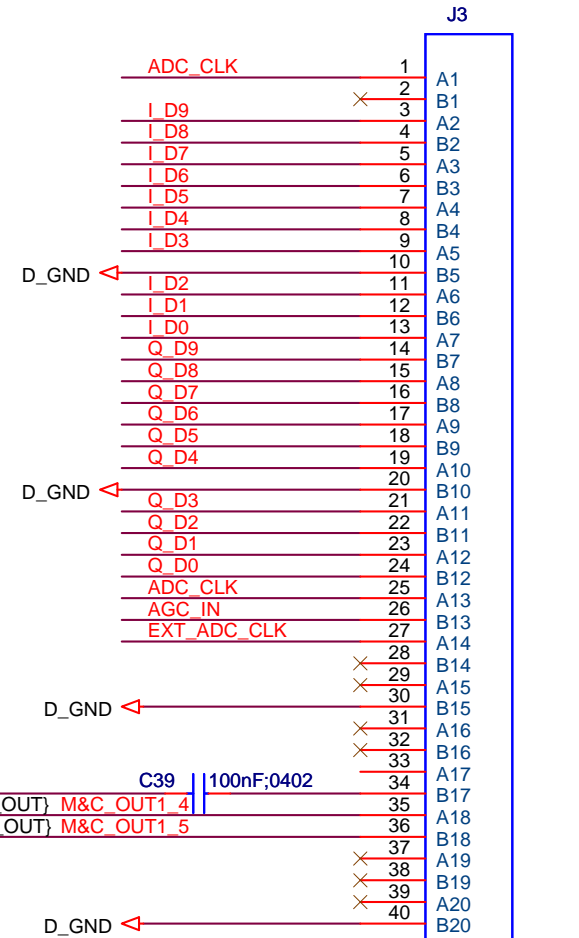

TMMH-120-01-L-D-RA

RIGHT OUTPUT  
CONNECTOR

PLL\_REF C39 | 100nF;0402

MS		
Mobile Satellite Services 18221A Flower Hill Way Gaithersburg, MD 20879 USA		
Title <b>COM-3010 / CONNECTOR</b>		
Size A	Document Number <b>Y08001</b>	Rev 3
Date: Thursday, June 24, 2010	Sheet 3 of 6	

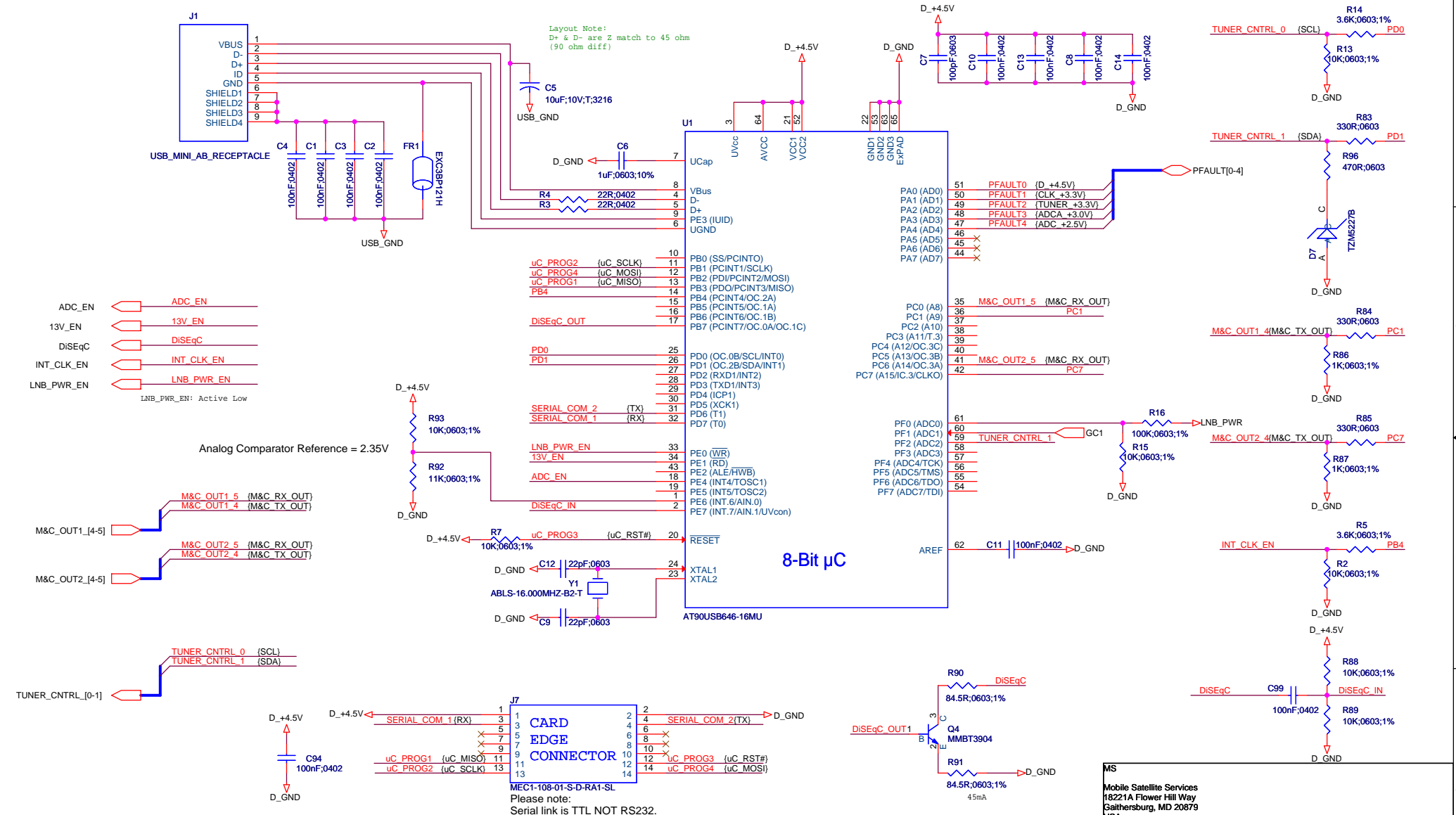

MS	
Mobile Satellite Services 18221A Flower Hill Way Gaithersburg, MD 20879 JSA	
Title <b>COM-3010 / MICRO</b>	
Size B	Document Number <b>Y08001</b>
Date: Thursday, June 24, 2010	Sheet 4 of 6
	Rev 3

### +5V Supply

OPERATIONAL RANGE: 4.75 - 5.25V

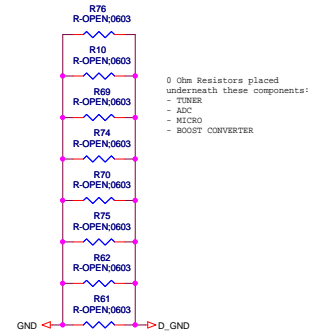
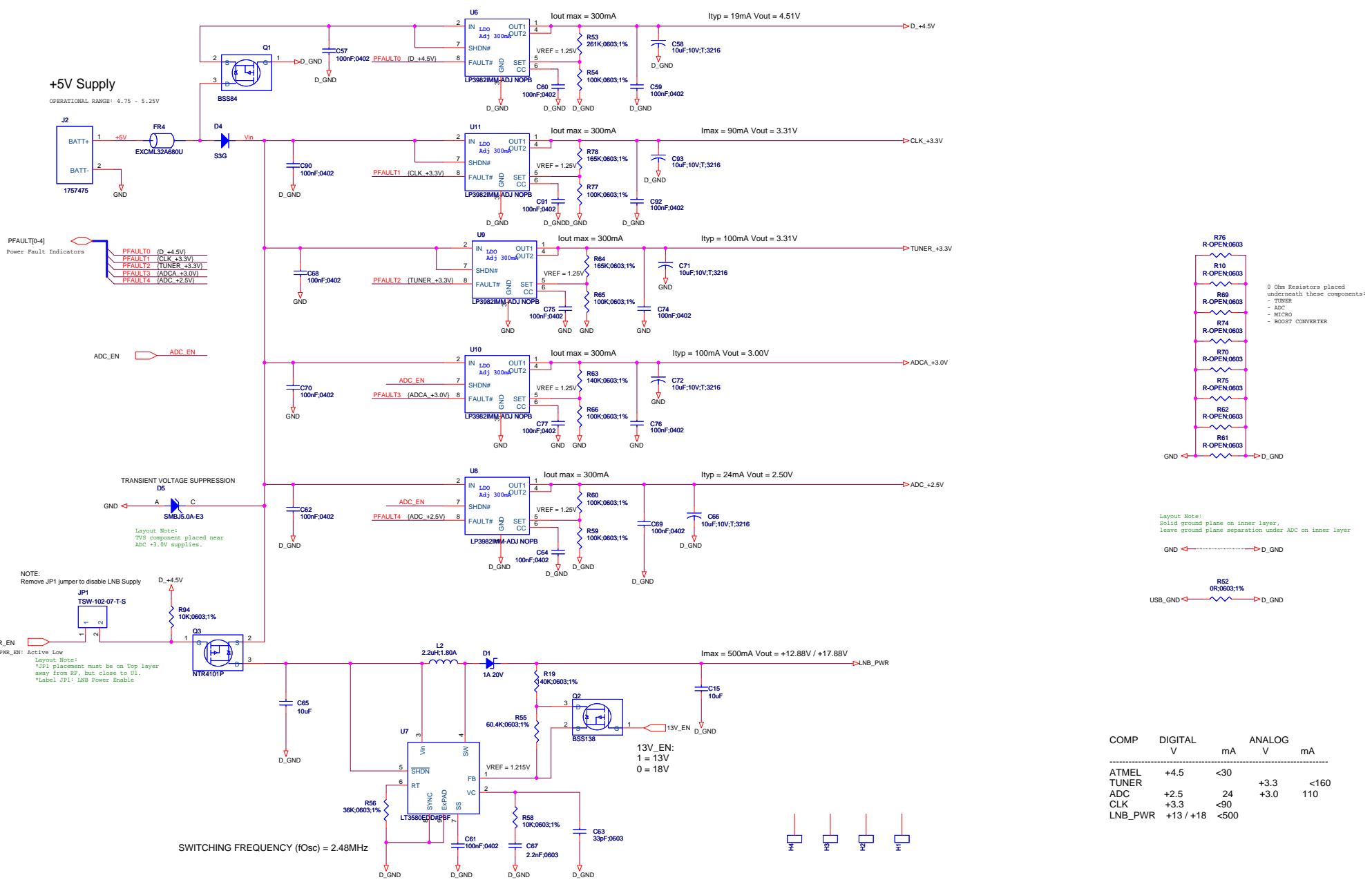

Layout Note:  
Solid ground plane on inner layer,  
leave ground plane separation under ADC on inner layer

COMP	DIGITAL V	mA	ANALOG V	mA
ATMEL	+4.5	<30		
TUNER	+2.5	24	+3.3	<160
ADC	+3.3	<90	+3.0	110
CLK	+3.3	<90		
LNB_PWR	+13/+18	<500		

SWITCHING FREQUENCY (f<sub>osc</sub>) = 2.48MHz

MS  
Mobile Satellite Services  
16221A Flower Hill Way  
Gaithersburg, MD 20878  
USA

Title  
**COM-3010 / POWER**

Size C Document Number  
**Y08001**

Date: Thursday, June 24, 2010 Sheet 5 of 6

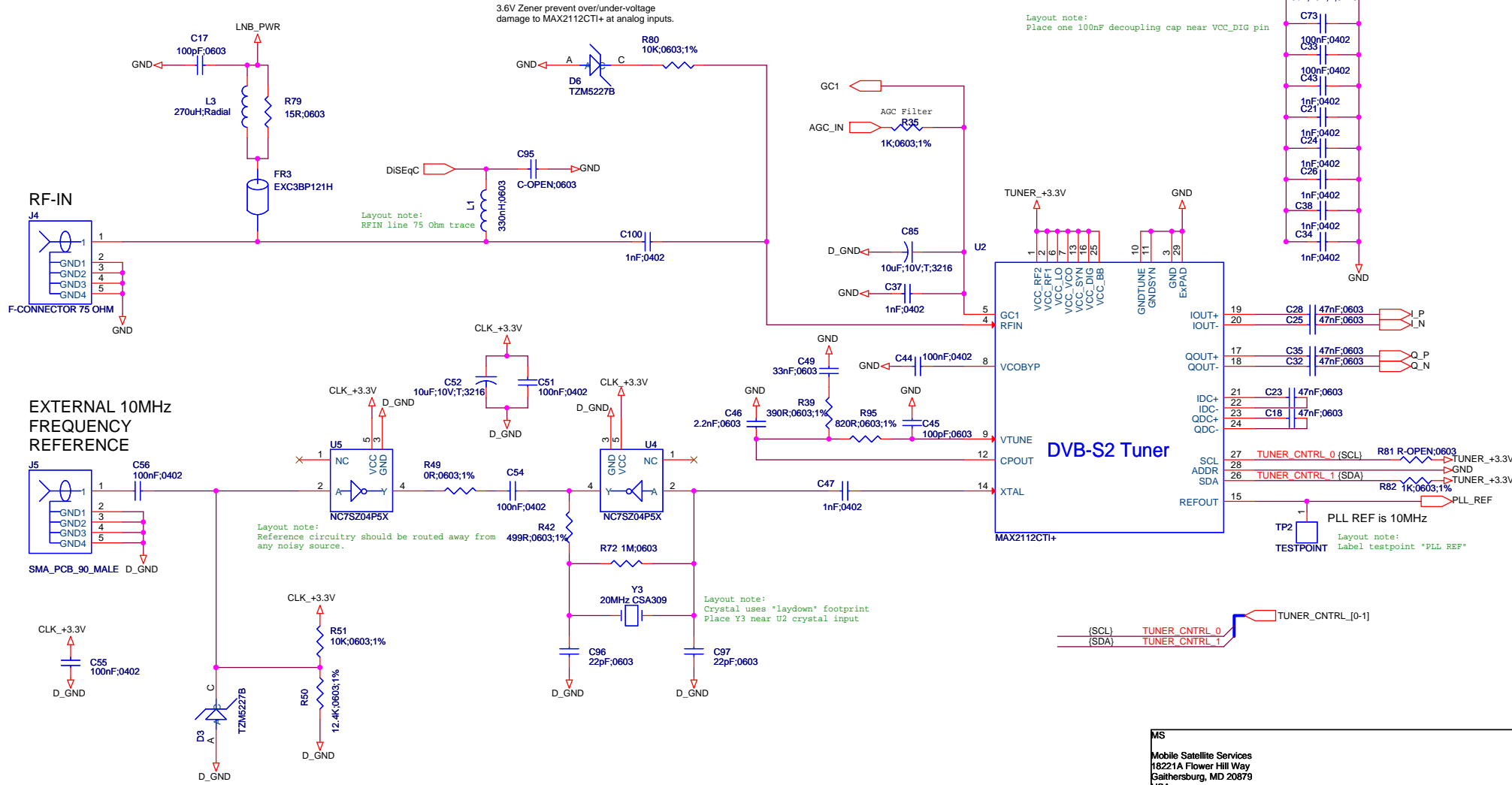

MS	
Mobile Satellite Services 18221A Flower Hill Way Gaithersburg, MD 20879 USA	
Title <b>COM-3010 / TUNER</b>	
Size B	Document Number <b>Y08001</b>
Date: Thursday, June 24, 2010	Sheet 6 of 6
	Rev 3