

TABLE OF CONTENTS

MAIN.....1	MICRO.....4
CONNECTOR.....2	POWER.....5
FPGA.....3	SDRAM.....6

Mobile Satellite Services

Christian K. Föhr
 18221A Flower Hill Way
 Gaithersburg, MD 20879
 USA

Title
ComBlock 8001 / ROOT

Size A	Document Number Y01013	Rev 1
-----------	----------------------------------	----------

Date: Tuesday, September 24, 2002 Sheet 1 of 6

40 Pin INPUT - Left

40 Pin OUTPUT

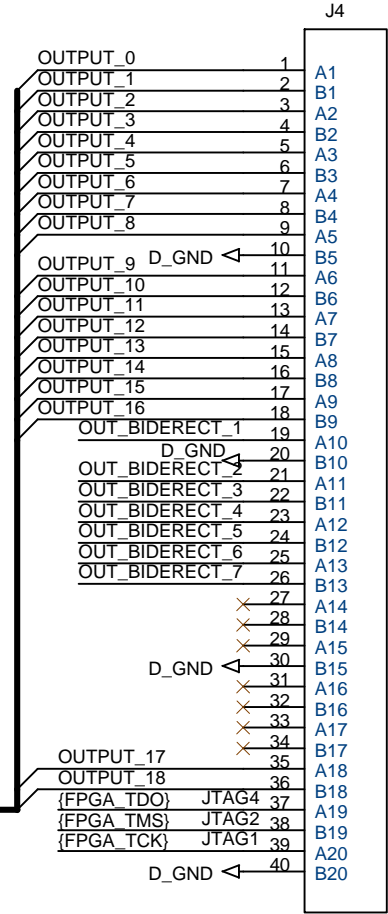
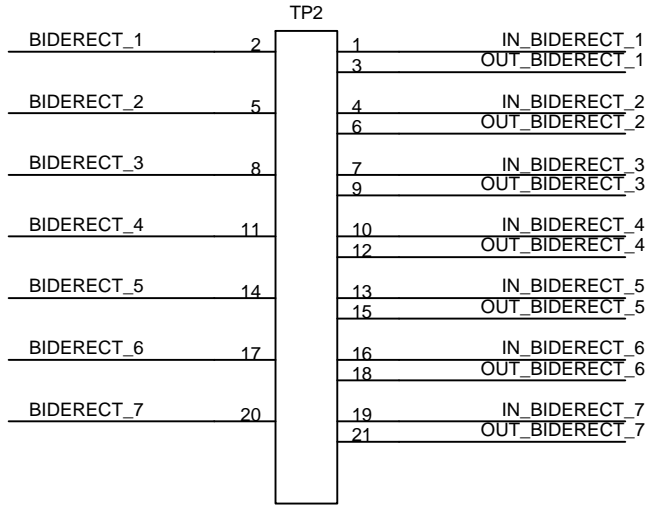
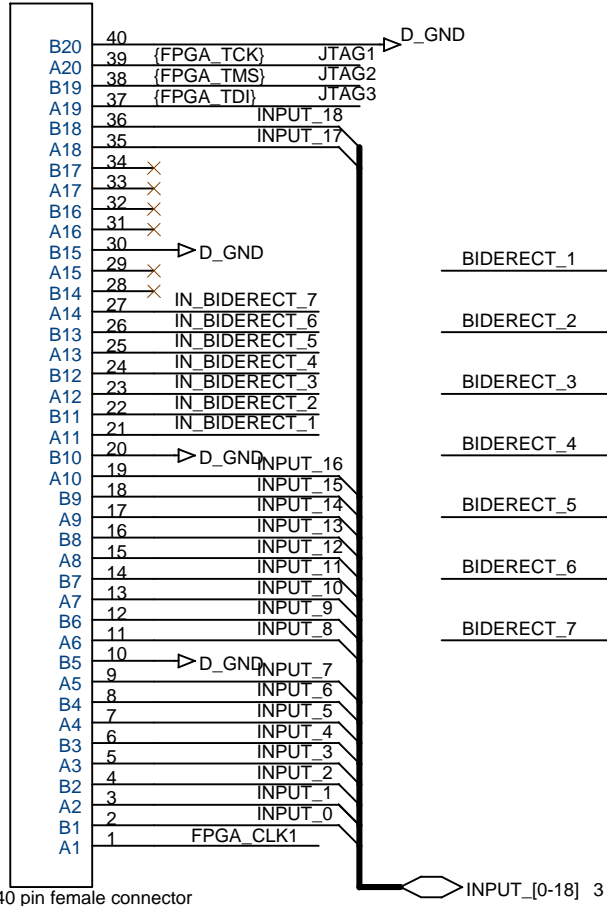

7P/3R/M_TM

3 OUTPUT_[0-18]

3 FPGA_CLK1

3 JTAG[1-4]

{FPGA_TDO} JTAG4
 {FPGA_TDI} JTAG3
 {FPGA_TMS} JTAG2
 {FPGA_TCK} JTAG1

3 BIDIRECT_[1-7]

BIDIRECT_1
 BIDIRECT_2
 BIDIRECT_3
 BIDIRECT_4
 BIDIRECT_5
 BIDIRECT_6
 BIDIRECT_7

Christian Föhr
 Mobile Satellite Services
 18221A Flower Hill Way
 Gaithersburg, MD 20879
 USA

Title
ComBlock 8001 / CONNECTOR

Size A	Document Number Y01013	Rev 1
-----------	----------------------------------	----------

Date: Tuesday, September 24, 2002 Sheet 2 of 6

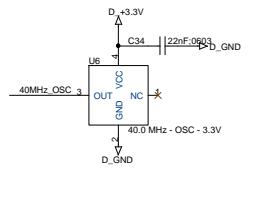
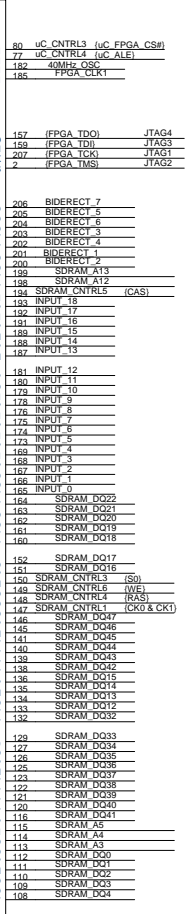
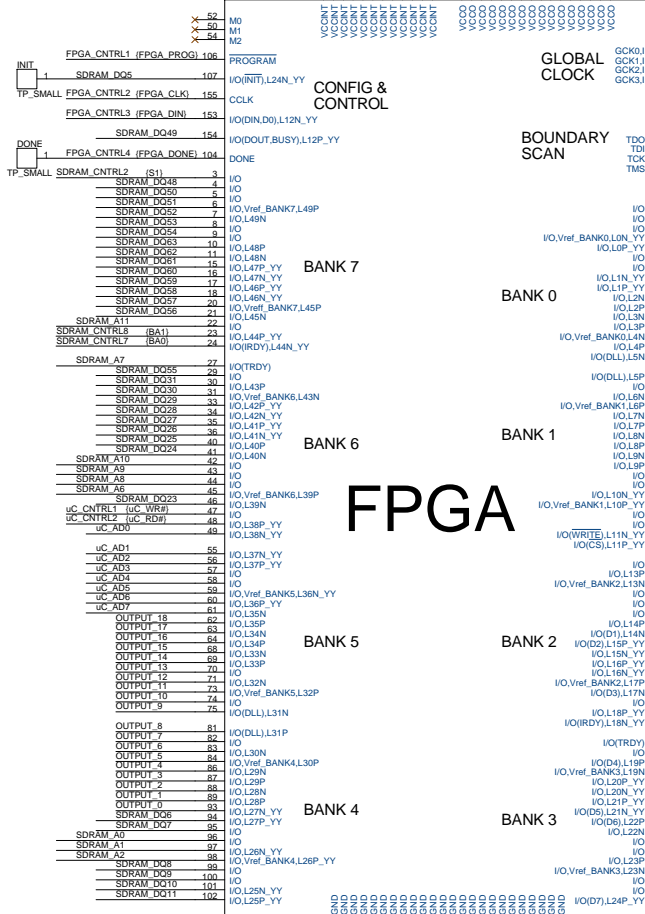
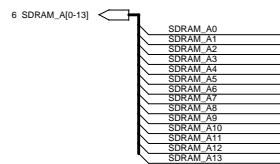
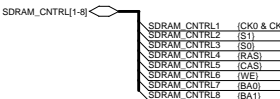
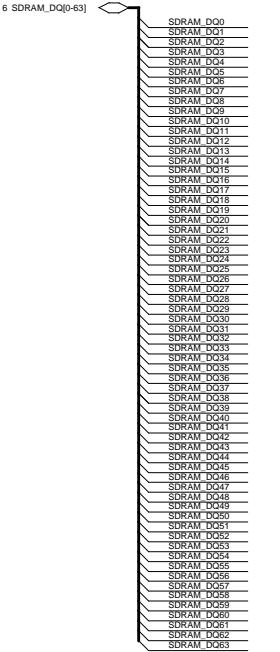
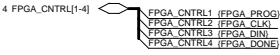
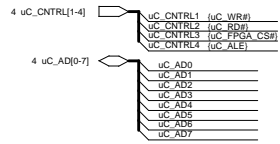

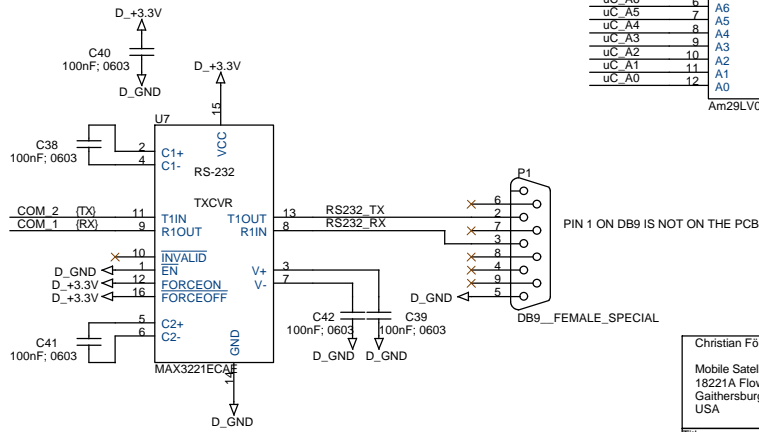
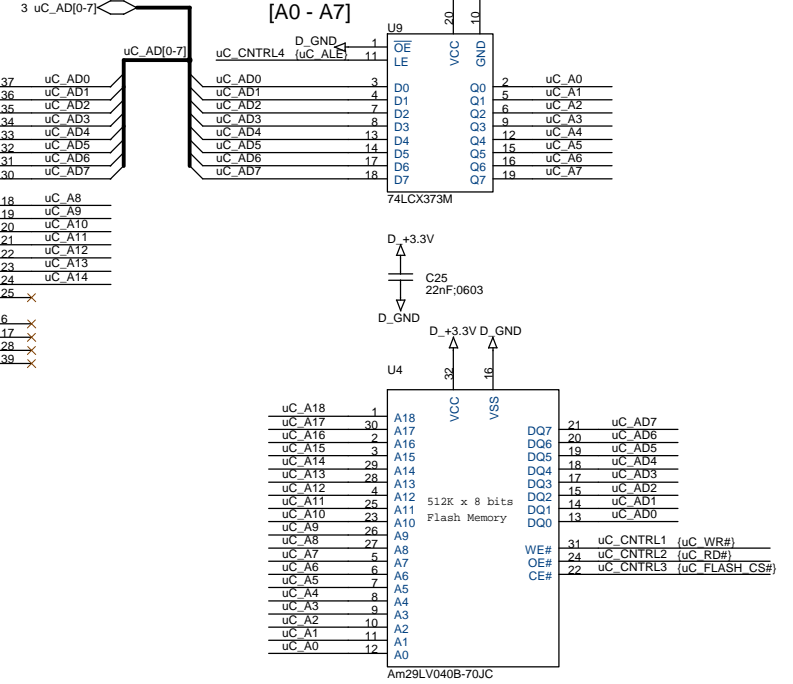
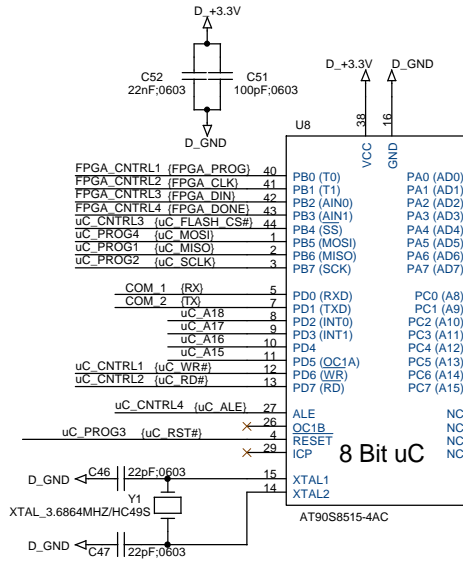
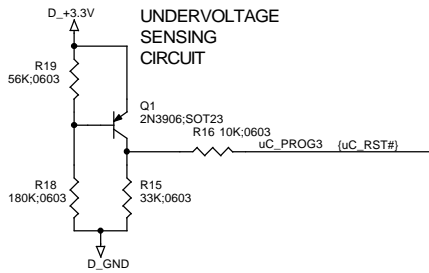
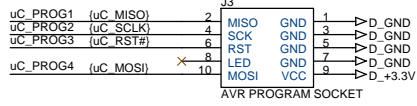
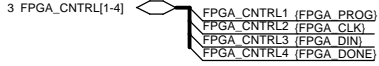
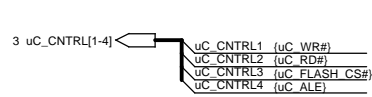

Christian Föhr
 Mobile Satellite Services
 18221A Flower Hill Way
 Gaithersburg, MD 20879
 USA

Title
ComBlock 8001 / MICROCONTROLLER

Size B Document Number **Y01013** Rev 1

Date: Tuesday, September 24, 2002 Sheet 4 of 6

+5 V Supply

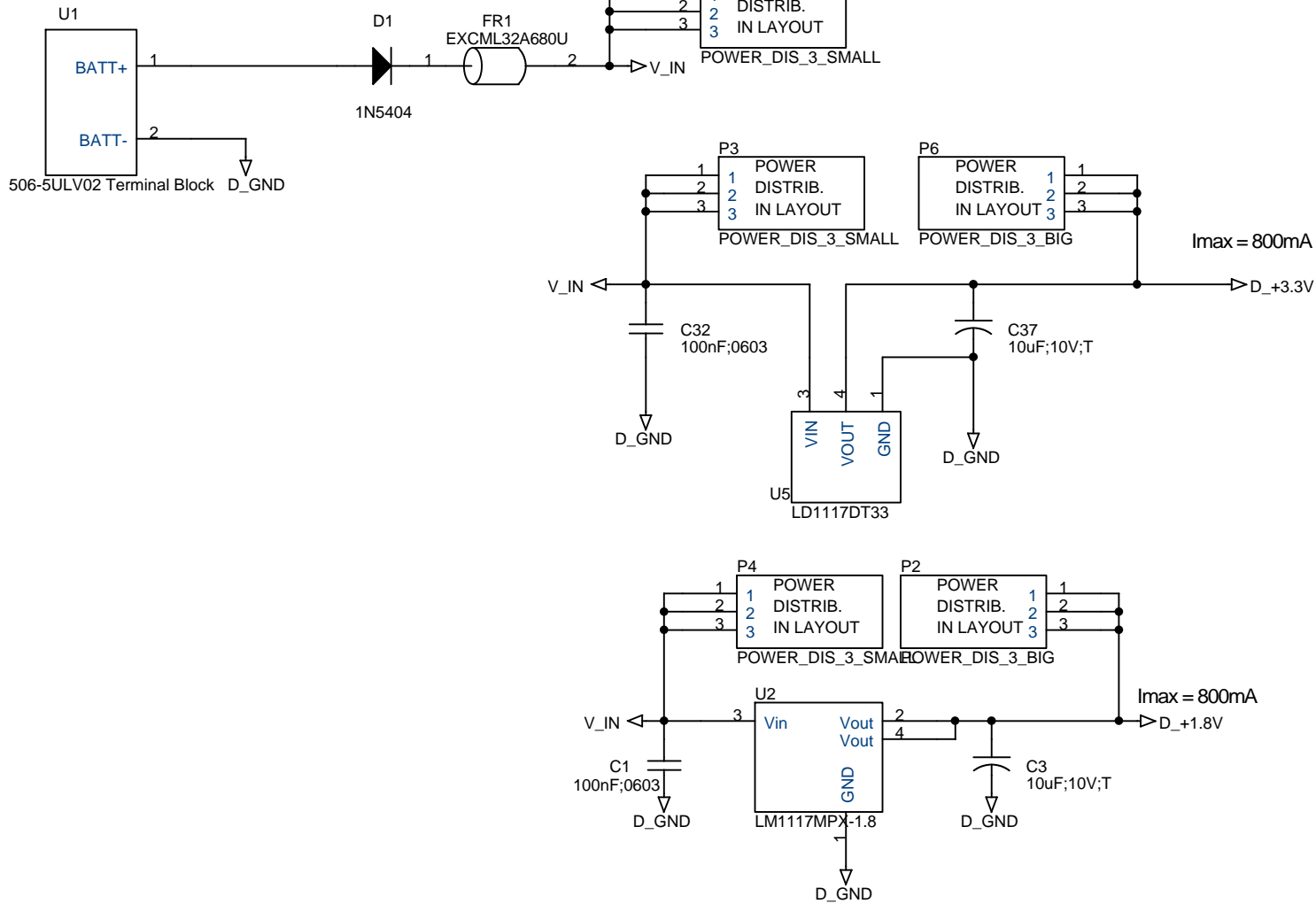

Christian Föhr
 Mobile Satellite Services
 18221A Flower Hill Way
 Gaithersburg, MD 20879
 USA

Title
ComBlock 8001 / POWER

Size A	Document Number Y01013	Rev 1
-----------	----------------------------------	----------

Date: Tuesday, September 24, 2002 Sheet 5 of 6

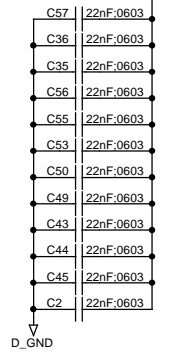
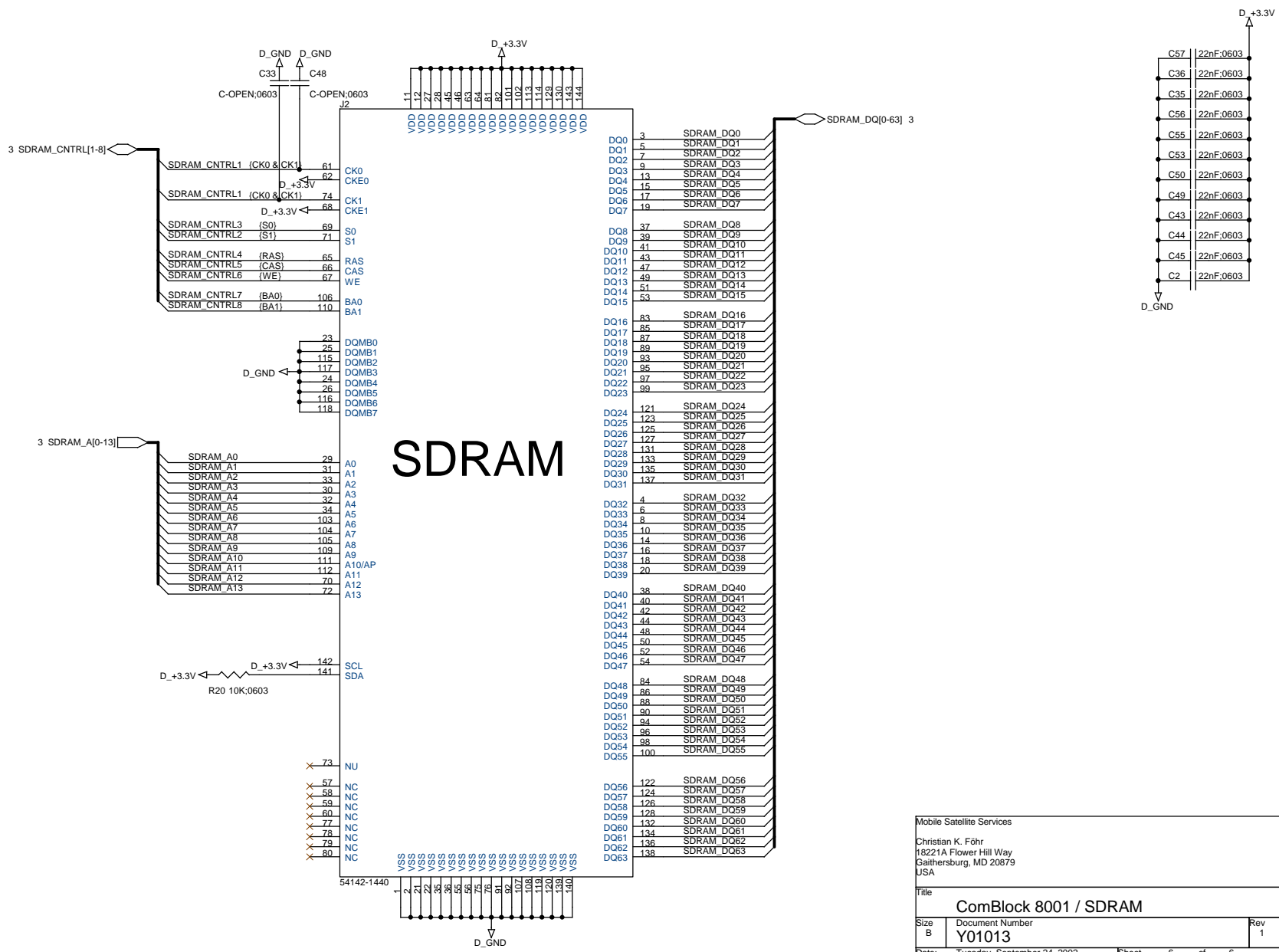

Mobile Satellite Services		
Christian K. Föhr 18221A Flower Hill Way Gaithersburg, MD 20879 USA		
Title ComBlock 8001 / SDRAM		
Size B	Document Number Y01013	Rev 1
Date: Tuesday, September 24, 2002	Sheet 6	of 6